

The better way to build™



Installation Manual ROOF SIPs



Thermapan
Structural
Insulated
Panels

ROOF SIPs Installation Manual

Table of Contents

Topics

General Requirements	3
Materials	3
Electrical Wiring	3
Interior Finish	4
Exterior Cladding	4
Materials Estimation	5

Details

Air Barrier Details for Air Barrier Sealants	AB-1
Air Barrier Details for Sealing SIP Connections	AB-2
Vapour Barrier Details for Vapour Sealing SIP Connections . . .	VB-1
Typical Roof Ridge	R-1
Roof Ridge Details for 12/12 Pitch Roof	R-2
Beam Pocket Detail	R-3
SIP Peak Connection (Alternative)	R-4
Roof Valley & Intermediate Roof Support	R-5
Eave Detail and Roof Support at Exterior Wall	R-6
Typical Sloped Roof Assembly	R-7
Sloped Roof Assembly with Ridge Beam	R-8
Flat Roof Assembly	R-9
Skylight Opening & Assembly	R-10
Typical Roof Connection Sections (Roof to Wall)	R-11
Roofing Applied to SIPs	R-12
Flat Roofing Applied to SIPs	R-13
LED Pot Light Installation in Ceiling SIPs	R-14
Ceiling Fan Attachment	R-15
Electrical Wire Fastened to Roof SIP	R-16
Pre-Fabricated Metal Chimney Installation	R-17
Screw Fastener Detail for Securing Load to Ceiling Panel	R-18
Roof SIP to ICF Connection	R-19
Roof Overhang Eave Details (Timberframe)	R-TF-1
Roof Overhang & Rake (Timberframe)	R-TF-2

ROOF SIPs

Installation Manual

1. General Requirements

1.1 Scope

The basic design and construction requirements for the Thermapan Structural Insulated Panel (SIP) roof system is set forth in this specification. Criteria for materials, environmental control, design loads, and structural design are included. Where requirements are based on internationally recognized standards and specifications, these standards and specifications are referenced without elaboration.

Installers shall reference engineering design package for fastening arrangements.

2. Materials

- 2.1** The Thermapan Roof SIP is composed of an expanded polystyrene (EPS) foam core laminated between two layers of oriented strand board (OSB) with a structural adhesive.
- 2.2** Framing Lumber shall be DOC PS 20 or NLGA No.2 or better.
- 2.3** Wire nails, ring nails, spikes and staples shall conform to CSA B111 or ANSI/ASME B11.1.
- 2.4** Wood screws shall conform to ANSI/ASME B18.6.1..
- 2.5** SIP screws shall conform to ICC-AC233.
- 2.6** Caulking Compounds shall conform to CAN/CGSB 19.13 or ASTM C 920.
- 2.7** Polyethylene Sheeting shall conform to CAN/CGSB-37.2, CAN/CGSB-37.16, or ASTM D 4397.
- 2.8** Low expansion foam seal shall conform to AAMA 812-04.
- 2.9** Structural adhesive shall conform to CAN/CGSB 71GP26, APA AFG-01 or ASTM D3498.

3. Electrical Wiring

- 3.1** An optional furring for electrical passage should be fastened to the underside of the roof SIP between the vapour barrier and the interior finish. See details R-1, R-4 and R-5.

4. Interior Finish

- 4.1** The interior of the roof SIP can be finished with any of the common required building code materials. It is recommended that the SIP joints and connections be sealed as per Details AB-1, AB-2 and VB-1.

5. Exterior Roofing

- 5.1** Consult your local building code and refer to details R-11 and R-12 for roofing applied to SIPs.

MATERIALS ESTIMATING
**Roof (Vaulted Ceiling)
Estimation Only**

Lumber Requirements:

- Perimeter of roof or fascia length

Caulking and Sealant Requirements:

- Every 1200 sqft (111 m²) of SIP equals 1 case of Expandable Foam
- Every 2000 sqft (185 m²) of SIP requires 1 case of Sealant

Fasteners:

- Recommend 2" (50mm) Ring nail or 2" (50mm) screws for connection to panel
- ~ 1.25 times the square footage of SIPs... nailing of spline
- SIP screws use 40% of Roof square footage

AIR BARRIER

RECOMMENDED DETAILS FOR AIR BARRIER SEALANTS

All sealants, FOAM (A) or CAULKING (B), should be applied onto the SIP in a continuous rectangular pattern along the outer most edge of the area to be sealed.

(A) A low expansion EXPANDABLE FOAM SEALANT should conform to the AAMA 812-04 standard. Apply a 1/2 inch or a 12.5 mm diameter of a *continuous* bead of expandable foam sealant onto the SIP:

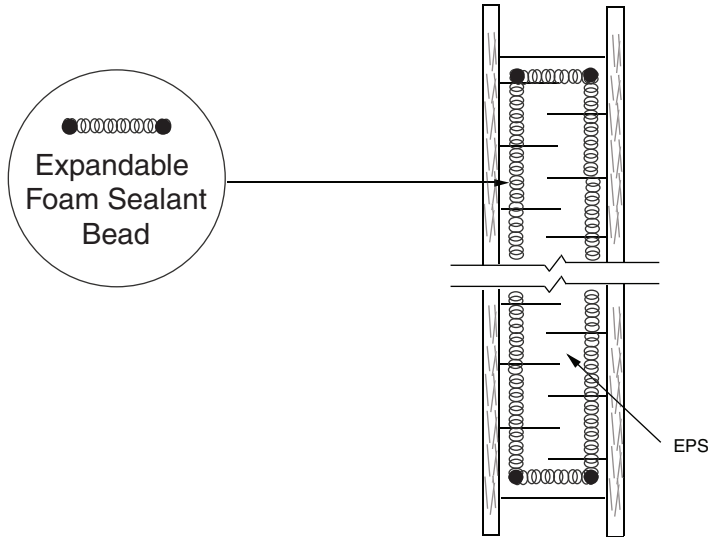

(B) A CAULKING SEALANT should conform to ASTM C920-02 and/or CAN/CGSB 19.13-M. Apply a 3/8 inch or a 10 mm diameter *continuous* bead of caulking onto the lumber spline:

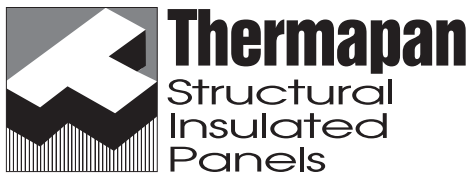
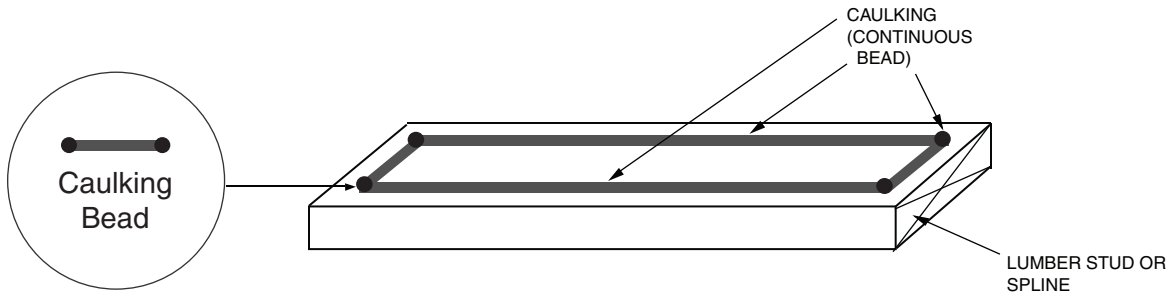

www.thermapan.com
1-877-443-WALL (9255)

TITLE		PROJECT	
AIR BARRIER DETAILS FOR AIR BARRIER SEALANTS			
REFERENCE	SCALE		
	N.T.S.		
DATE	REVISION	DWG. No.	
NOVEMBER 2010	1	AB-1	

AIR BARRIER

RECOMMENDED DETAILS FOR SEALING SIP CONNECTIONS

(1) Foam to Foam: Use a low expansion foam sealant.

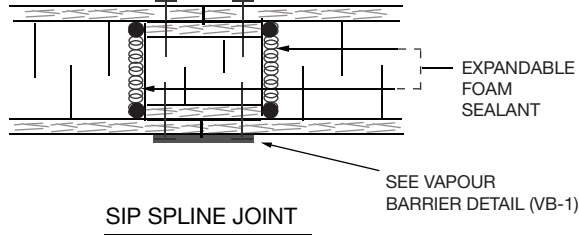

(2) Foam to Wood: Use a low expansion foam sealant.

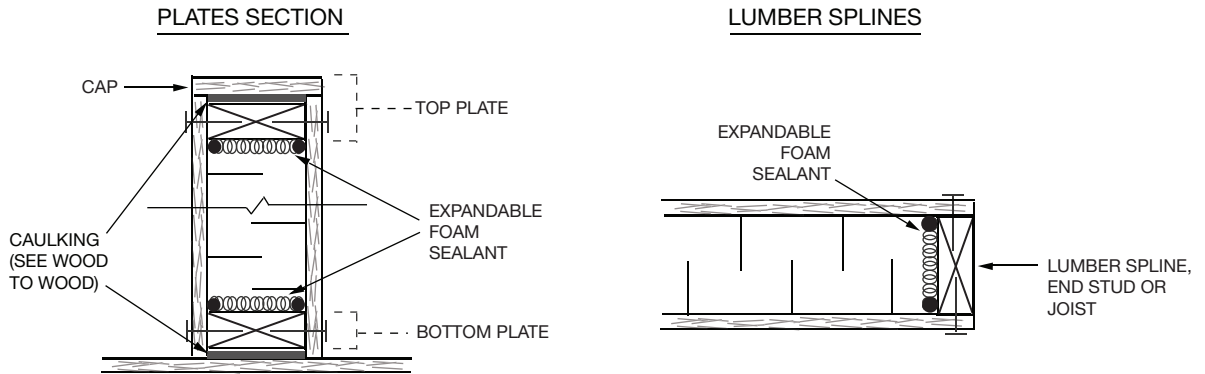

(3) Wood to Wood: Use caulking and a low expansion foam sealant.

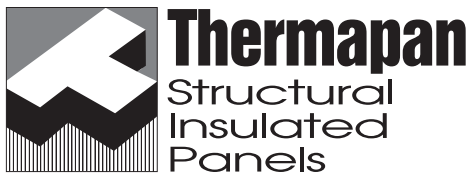
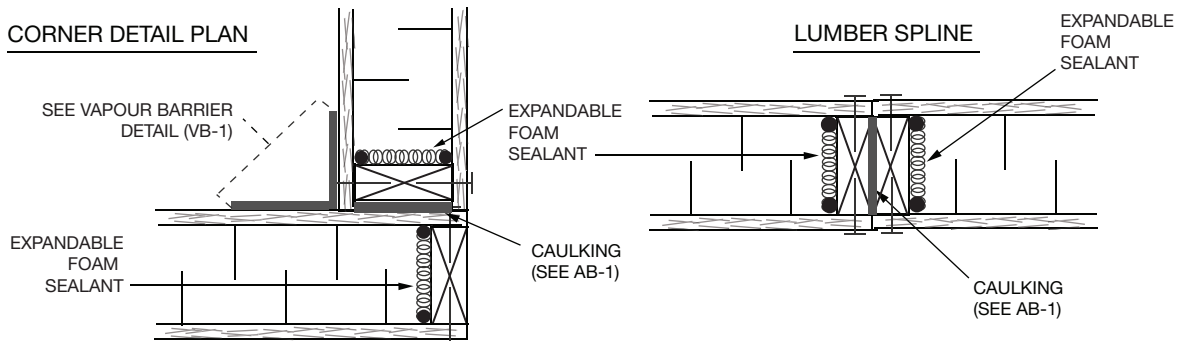

www.thermapan.com
1-877-443-WALL (9255)

TITLE		PROJECT	
AIR BARRIER DETAILS FOR SEALING SIP CONNECTIONS			
REFERENCE	SCALE		
	N.T.S.		
DATE	REVISION	DWG. No.	
MAY 2020	1	AB-2	

VAPOUR BARRIER

RECOMMENDED DETAILS FOR VAPOUR SEALING SIP CONNECTIONS

The function of a vapour barrier is to control the entry of water vapour into the building assembly. Vapour barriers should not be confused with an air barrier.

All SIP seams and connections must be VAPOUR SEALED from the INTERIOR.

These are recommended vapour barrier methods:

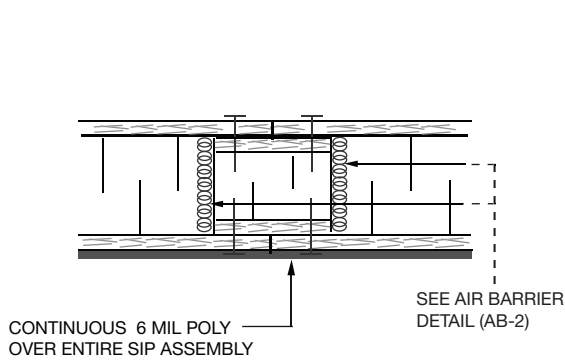

CONTINUOUS 6 MIL POLY
RECOMMENDED

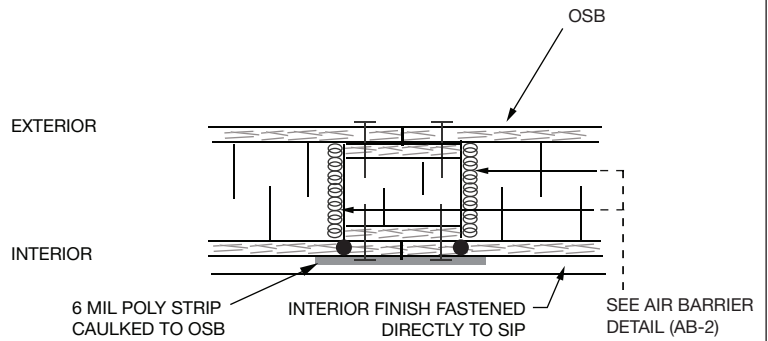

6 MIL POLY STRIPS & CAULKING

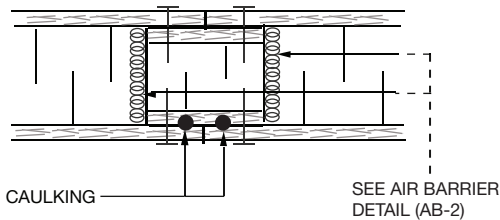

CAULKING

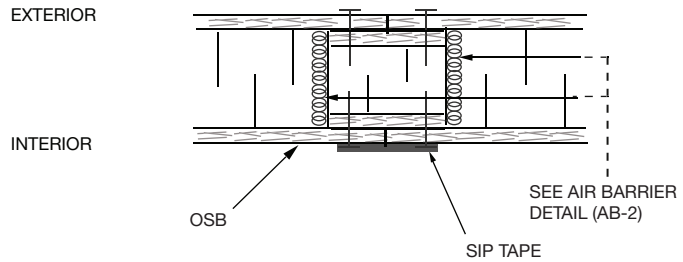

SIP TAPE

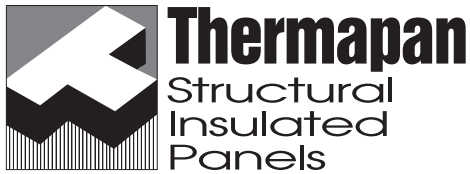

www.thermapan.com
1-877-443-WALL (9255)

TITLE		PROJECT	
VAPOUR BARRIER DETAILS FOR VAPOUR SEALING SIP CONNECTIONS			
REFERENCE	SCALE		
	N.T.S.		
DATE	REVISION	DWG. No.	
MAY 2020	2	VB-1	

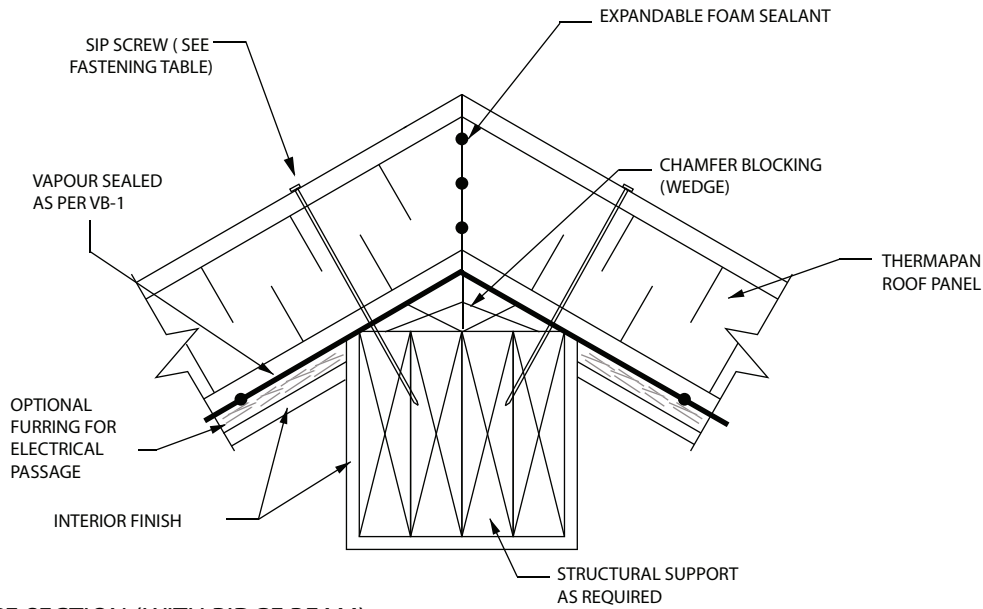

RIDGE SECTION (WITH RIDGE BEAM)

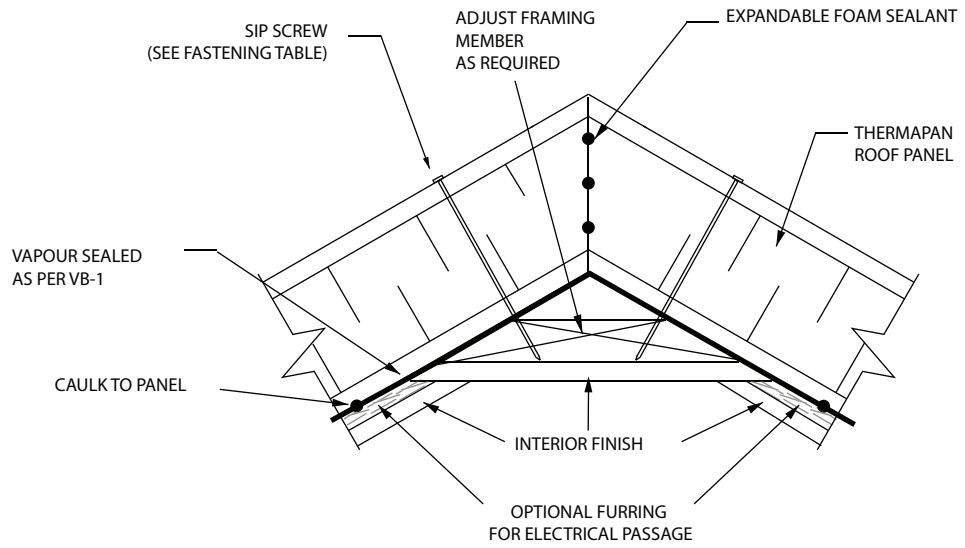

"RIDGE" SECTION (NO RIDGE BEAM)

NOTE: REFERENCE ROOF PANEL FASTENING TABLE ON CONNECTION DESIGN (CD) SHEET OF ENGINEERED SHOP DRAWINGS



Thermapan
Structural
Insulated
Panels

www.thermapan.com
1-877-443-WALL (9255)

TITLE		PROJECT	
ROOF RIDGE DETAILS			
REFERENCE	SCALE	N.T.S.	
DATE	REVISION	DWG. No.	
FEBRUARY 2012	5	R-1	

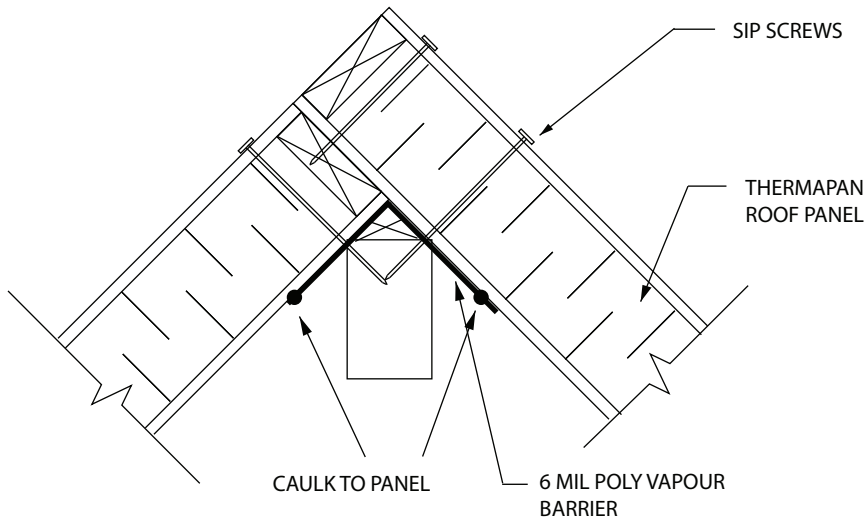

RIDGE SECTION (TYPICAL RIDGE BEAM)

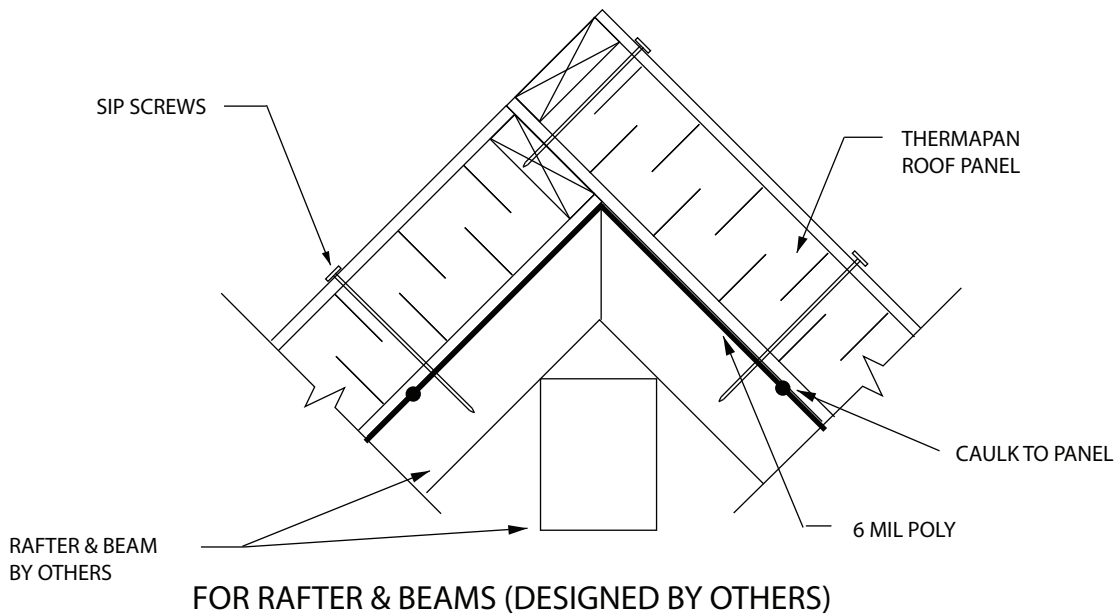

FOR RAFTER & BEAMS (DESIGNED BY OTHERS)

NOTE: REFER TO AIR BARRIER (AB-2) AND VAPOUR BARRIER (VB-1) DETAILS FOR SEALING SIP CONNECTIONS
 NOTE: REFERENCE ROOF PANEL FASTENING TABLE ON CONNECTION DESIGN (CD) SHEET OF ENGINEERED SHOP DRAWINGS

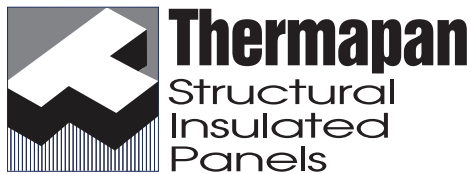

www.thermapan.com
 1-877-443-WALL (9255)

TITLE		SECTION - ROOF RIDGE DETAILS FOR 12/12 PITCH ROOF		PROJECT
REFERENCE	SCALE		N.T.S.	
DATE	REVISION	DWG. No.		
FEBRUARY 2012	R-2	R-2		

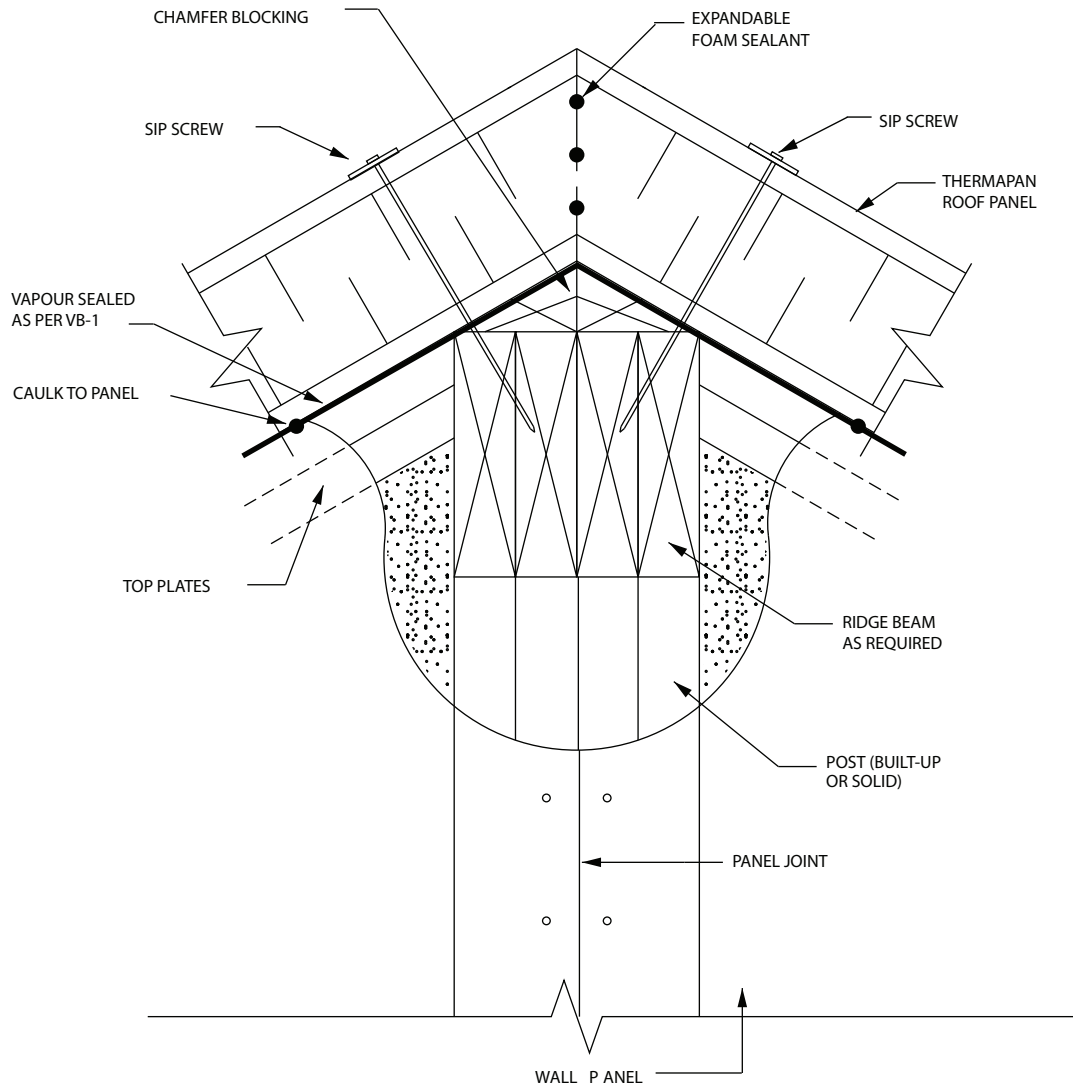

RIDGE BEAM & POST POCKET

NOTE: REFERENCE ROOF PANEL FASTENING TABLE ON CONNECTION DESIGN (CD) SHEET OF ENGINEERED SHOP DRAWINGS

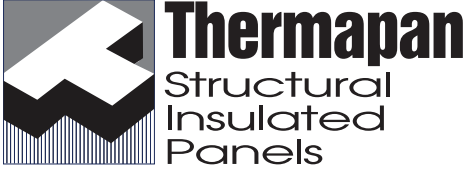
 <p>www.thermapan.com 1-877-443-WALL (9255)</p>	TITLE		PROJECT	
	<p>BEAM POCKET DETAIL</p>			
	REFERENCE	SCALE		<p>N.T.S.</p>
	DATE	REVISION	DWG. No.	
	DECEMBER 2010	2	R-3	

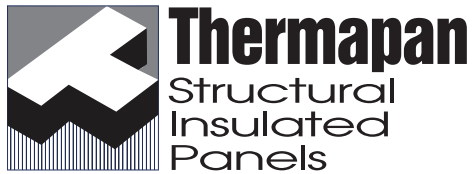
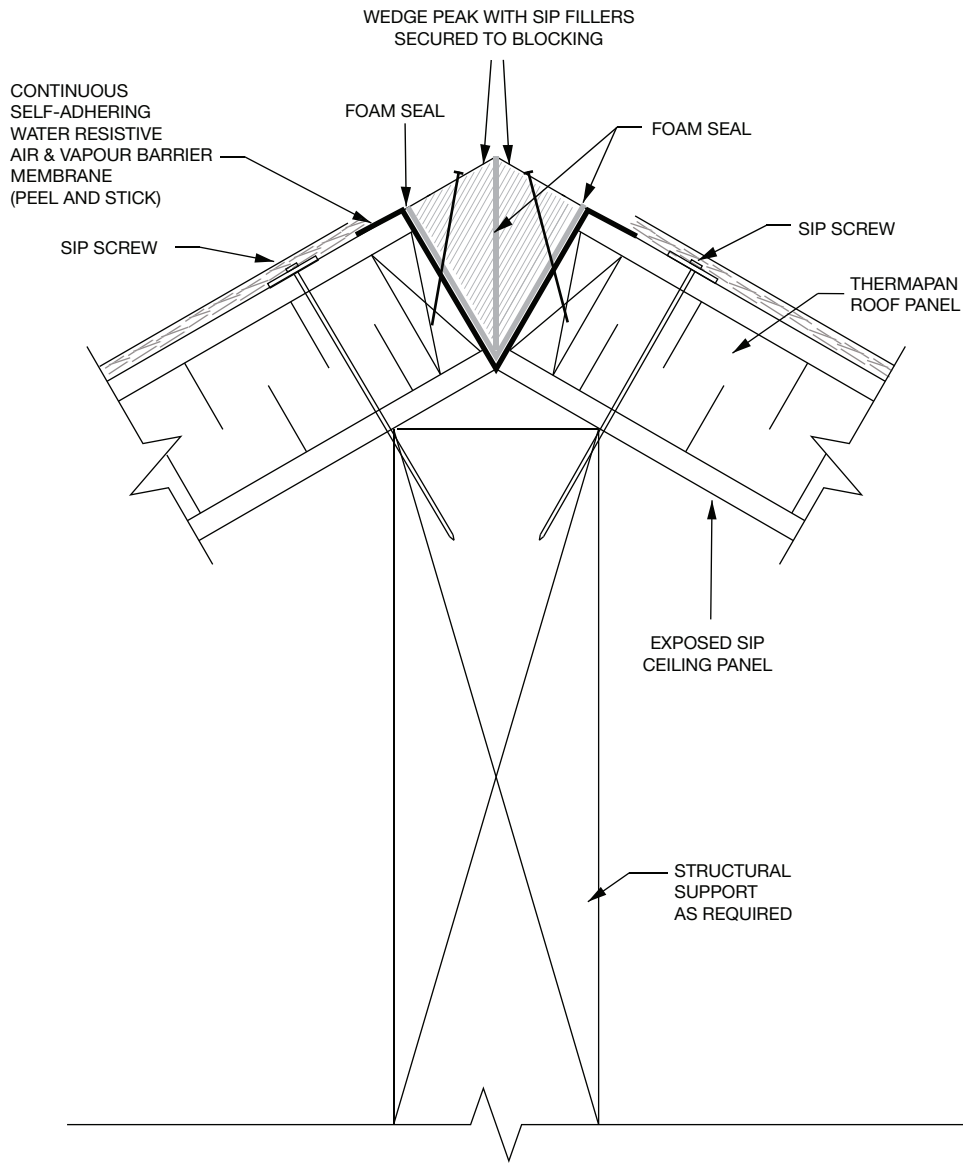

www.thermapan.com
1-877-443-WALL (9255)

TITLE		PROJECT	
SIP PEAK CONNECTION (ALTERNATIVE)		PROJECT	
		PROJECT	
REFERENCE	SCALE	N.T.S.	
DATE	REVISION	DWG. No.	
JUNE 2023	1	R-4	

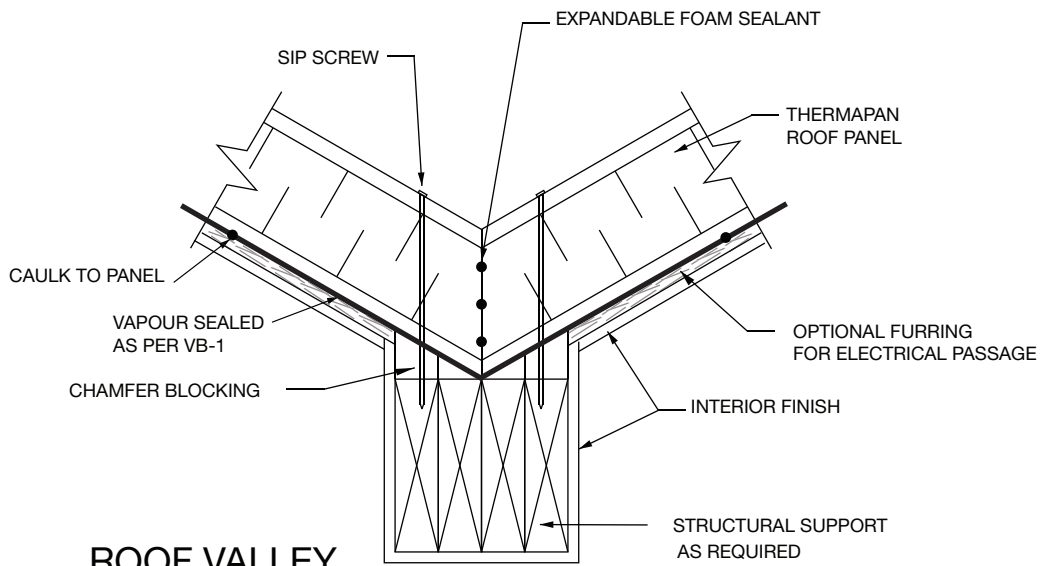

ROOF VALLEY

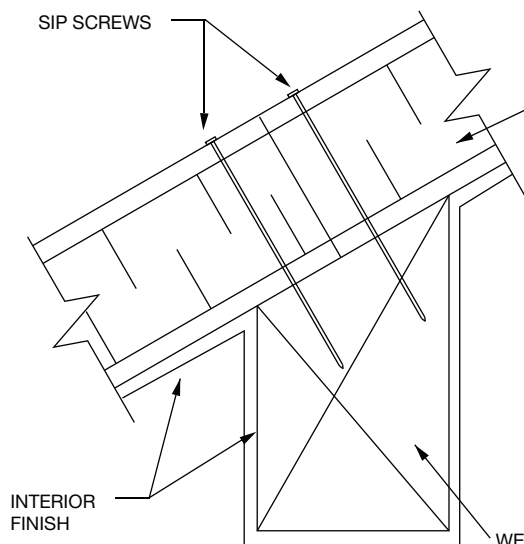

PANEL JOINT AT ROOF SUPPORT

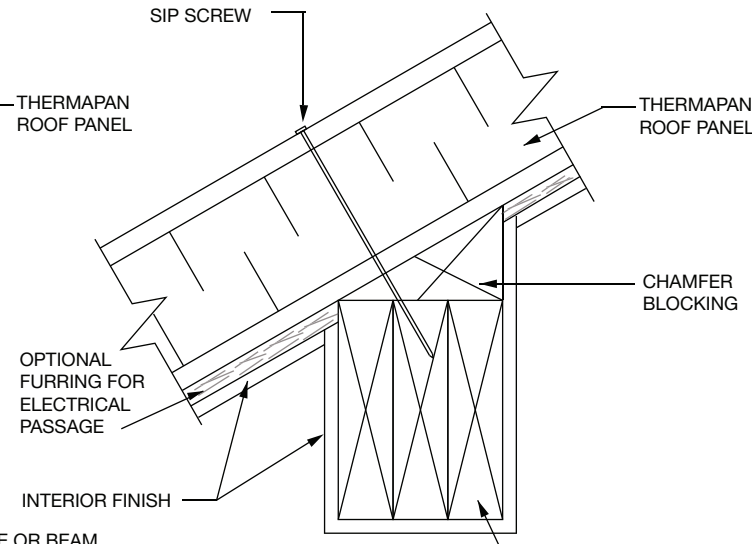

PANEL CONTINUES OVER ROOF SUPPORT

NOTE: REFERENCE ROOF PANEL FASTENING TABLE ON CONNECTION DESIGN (CD) SHEET OF ENGINEERED SHOP DRAWINGS

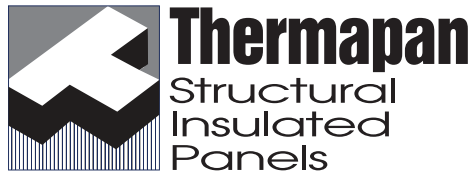

www.thermapan.com
1-877-443-WALL (9255)

TITLE		PROJECT	
ROOF VALLEY & INTERMEDIATE ROOF SUPPORT			
REFERENCE	SCALE		
	N.T.S.		
DATE	REVISION	DWG. No.	
JULY 2018	4	R-5	

ROOF SUPPORT WITH OVERHANG

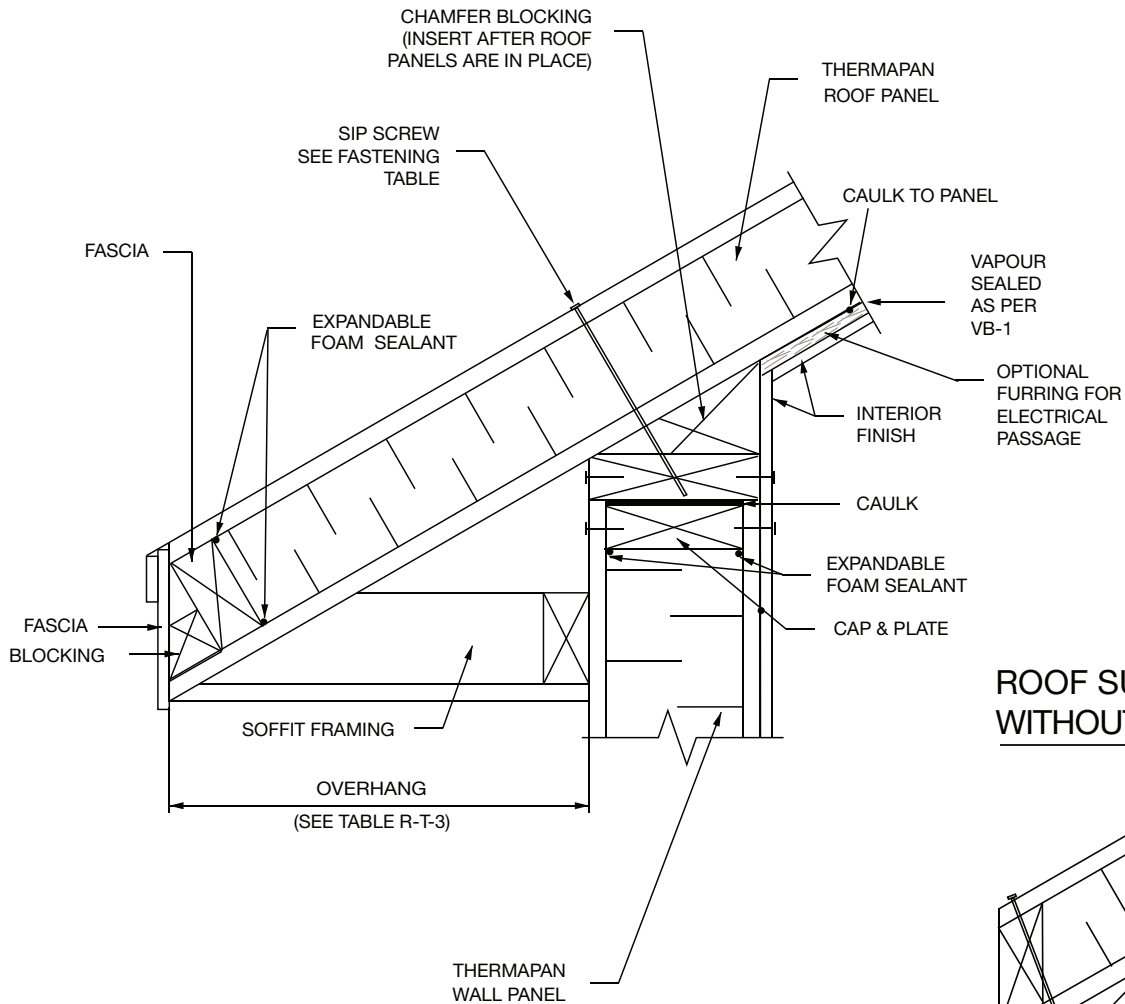

ROOF SUPPORT WITHOUT OVERHANG

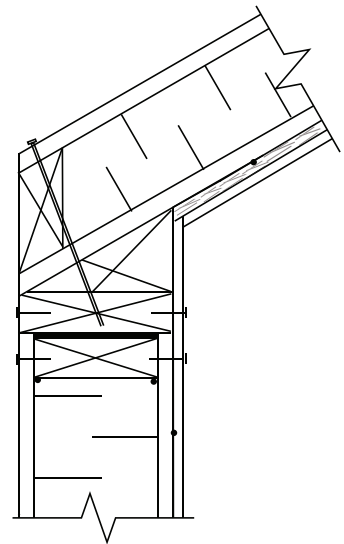

NOTE: REFERENCE ROOF PANEL FASTENING TABLE ON CONNECTION DESIGN (CD) SHEET OF ENGINEERED SHOP DRAWINGS

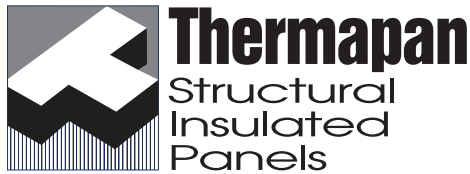

www.thermapan.com
1-877-443-WALL (9255)

TITLE		PROJECT	
EAVE DETAIL & ROOF SUPPORT AT EXTERIOR WALL			
REFERENCE	SCALE		
	N.T.S.		
DATE	REVISION	DWG. No.	
MARCH 2020	7	R-6	

**SECTION
A-A**

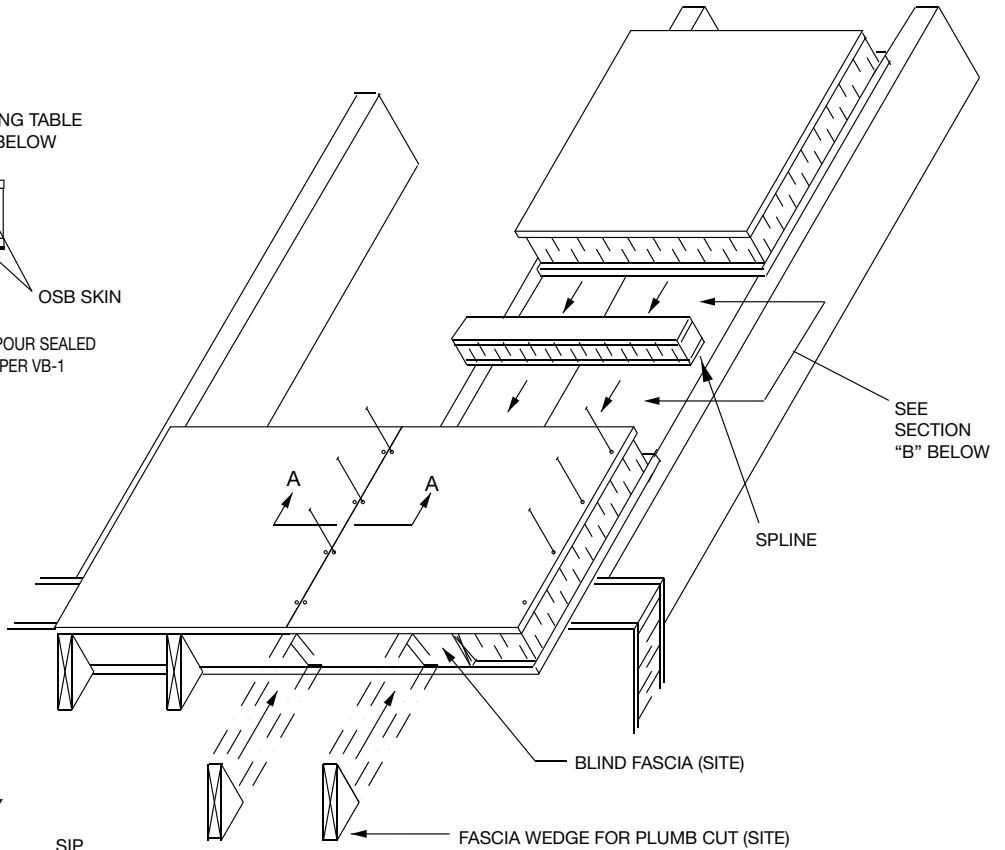
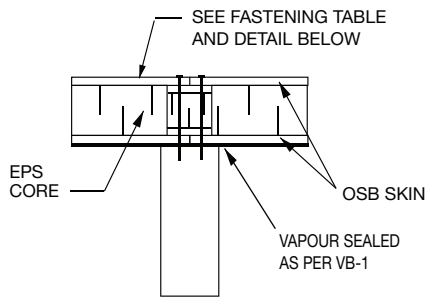

**ROOF ASSEMBLY
SECTION B**

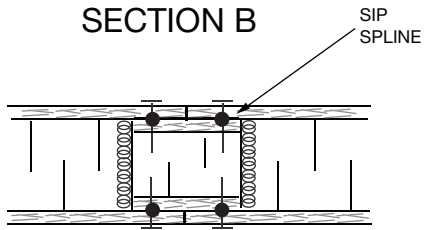

NOTE: REFER TO AIR BARRIER (AB-2) AND VAPOUR BARRIER (VB-1) DETAILS FOR SEALING SIP CONNECTIONS.

NOTE: REFERENCE ROOF PANEL FASTENING TABLE ON CONNECTION DESIGN (CD) SHEET OF ENGINEERED SHOP DRAWINGS

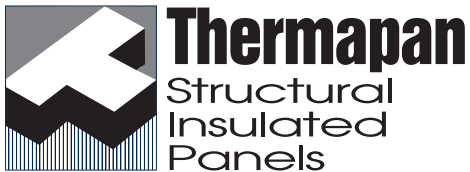

www.thermapan.com
1-877-443-WALL (9255)

TITLE		PROJECT	
TYPICAL SLOPED ROOF ASSEMBLY			
REFERENCE	SCALE		
	N.T.S.		
DATE	REVISION	DWG. No.	
FEBRUARY 2012	6	R-7	

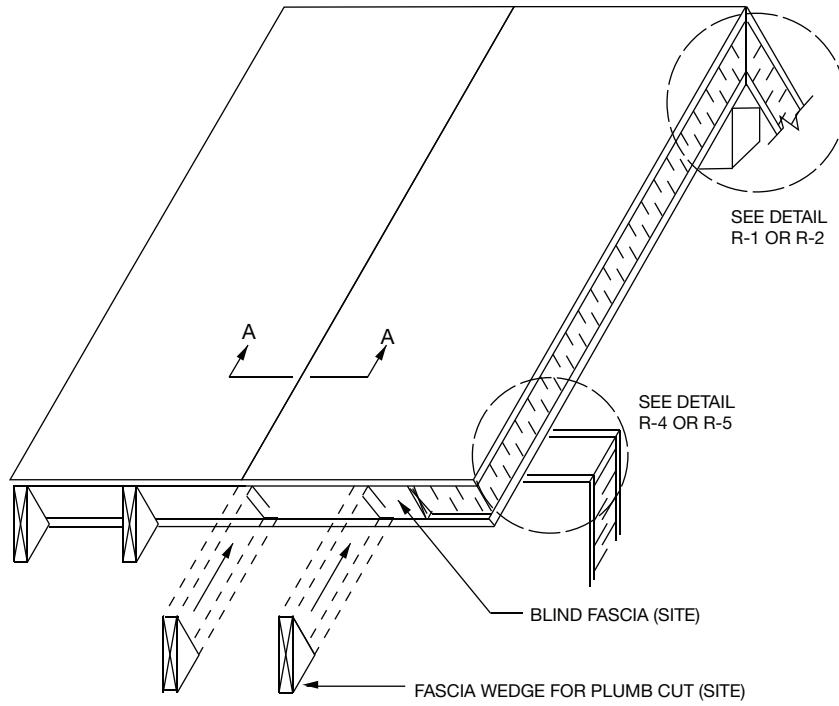

ROOF ASSEMBLY SECTION A-A

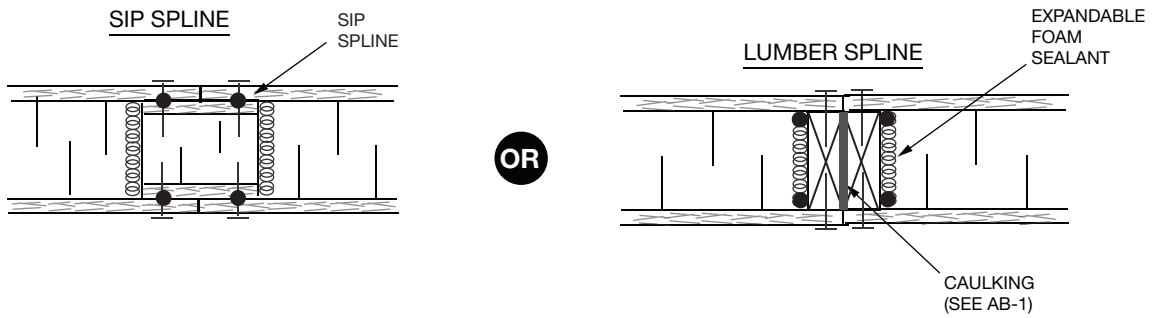

NOTE: REFER TO AIR BARRIER (AB-2) AND VAPOUR BARRIER (VB-1) DETAILS FOR SEALING SIP CONNECTIONS.
 NOTE: REFERENCE ROOF PANEL FASTENING TABLE ON CONNECTION DESIGN (CD) SHEET OF ENGINEERED SHOP DRAWINGS

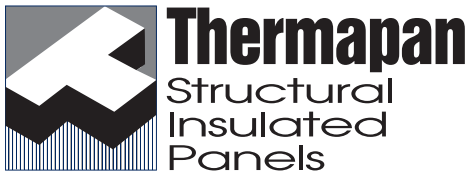

www.thermapan.com
 1-877-443-WALL (9255)

TITLE		PROJECT	
SLOPED ROOF ASSEMBLY WITH RIDGE BEAM			
REFERENCE	SCALE		
	N.T.S.		
DATE	REVISION	DWG. No.	
FEBRUARY 2012	2	R-8	

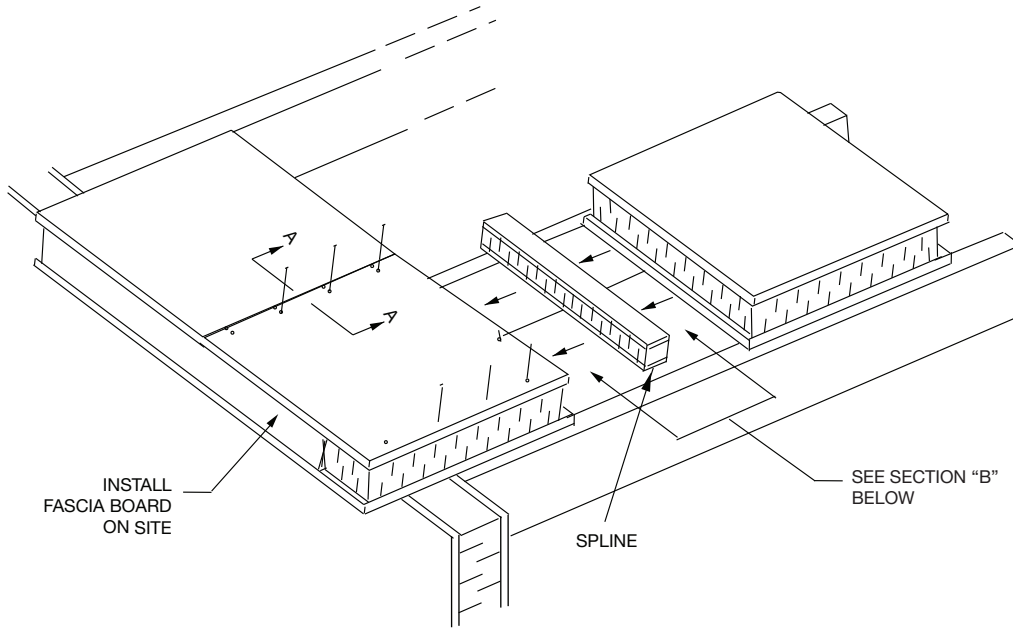

**SECTION
A-A**

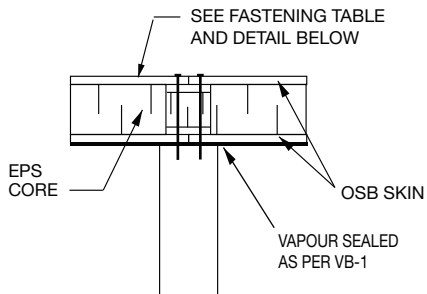

**SECTION B
ISOMETRIC ROOF ASSEMBLY
GENERIC DETAIL FOR FLAT ROOF**

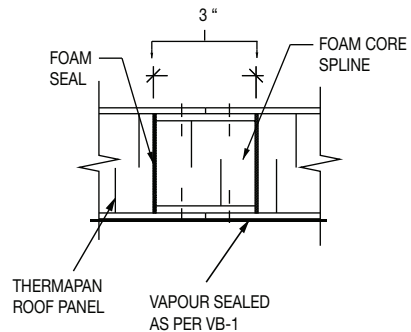

NOTE: REFER TO AIR BARRIER (AB-2) AND VAPOUR BARRIER (VB-1) DETAILS FOR SEALING SIP CONNECTIONS.

NOTE: REFERENCE ROOF PANEL FASTENING TABLE ON CONNECTION DESIGN (CD) SHEET OF ENGINEERED SHOP DRAWINGS

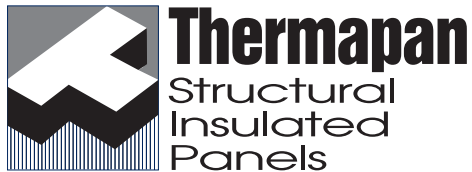

www.thermapan.com
1-877-443-WALL (9255)

TITLE		PROJECT	
FLAT ROOF ASSEMBLY			
REFERENCE	SCALE	N.T.S.	
DATE	REVISION		
FEBRUARY 2012	3	DWG. No.	R-9

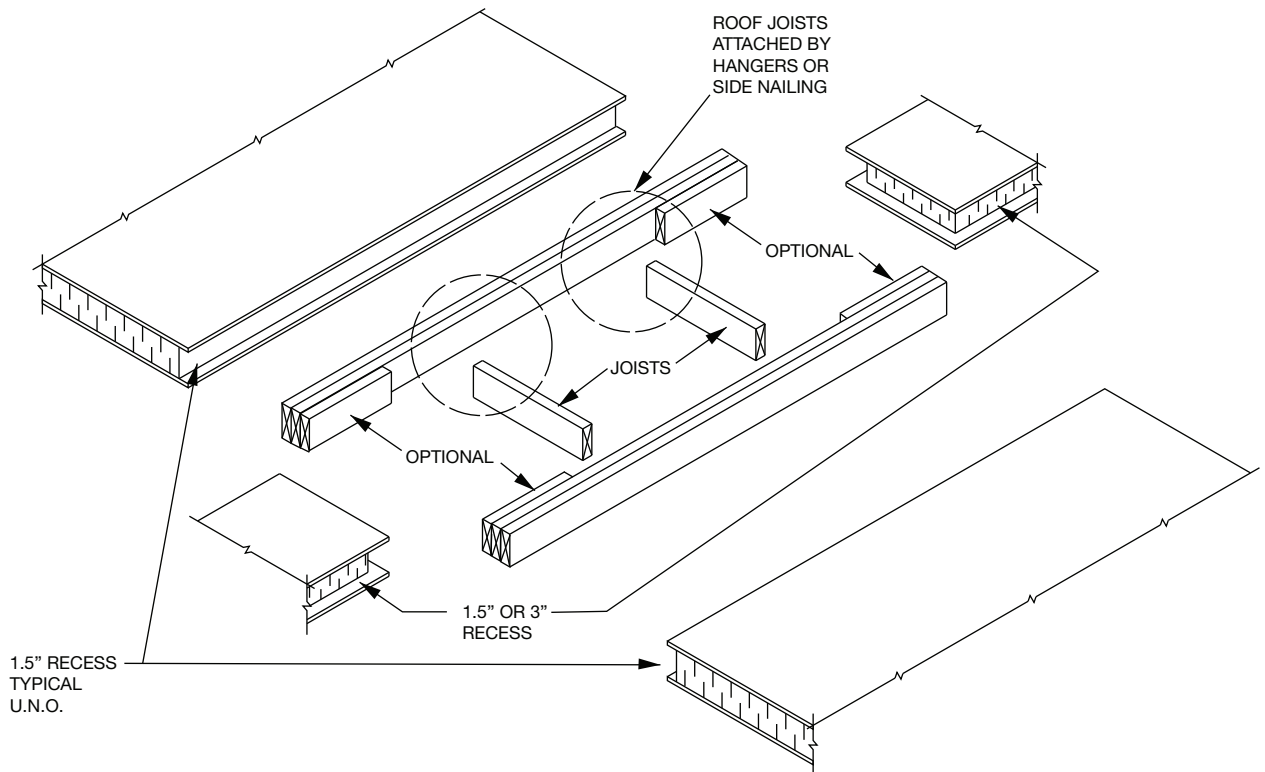

1.5" RECESS
TYPICAL
U.N.O.

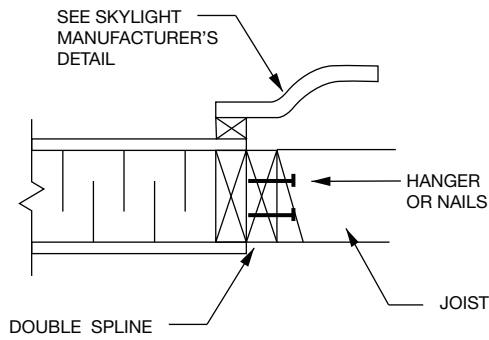

Thermapan
Structural
Insulated
Panels

www.thermapan.com
1-877-443-WALL (9255)

TITLE		PROJECT	
SKYLIGHT OPENING & ASSEMBLY			
REFERENCE	SCALE		
	N.T.S.		
DATE	REVISION	DWG. No.	
FEBRUARY 2012	3	R-10	

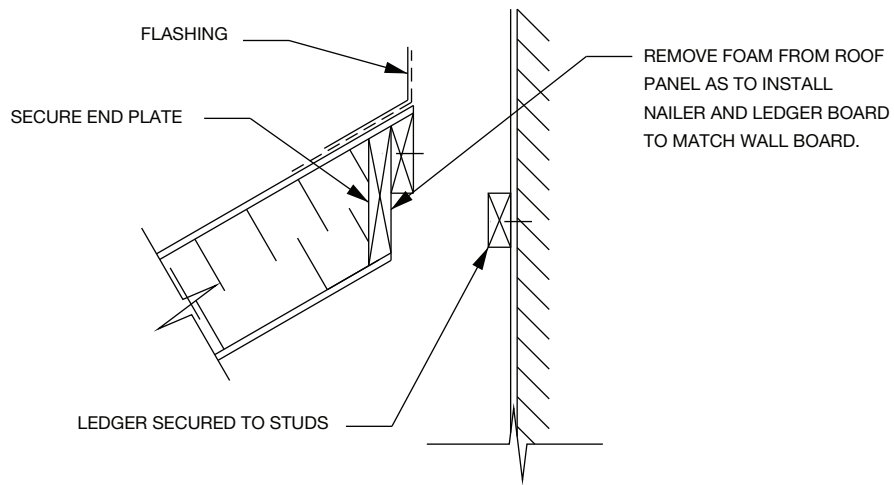

OPTION 1

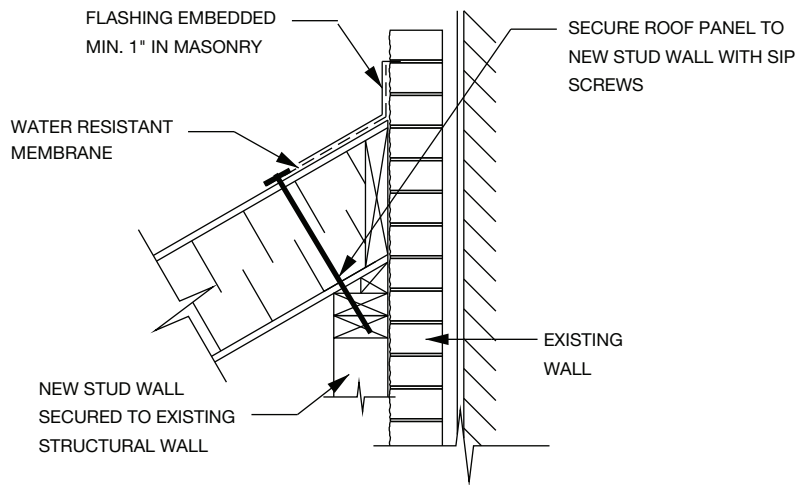

OPTION 2

NEW ROOF TO EXISTING WALL



Thermapan
Structural
Insulated
Panels

www.thermapan.com
1-877-443-WALL (9255)

TITLE		PROJECT	
REFERENCE		SCALE	
DATE		REVISION	
DATE		DWG. No.	
FEBRUARY 2012		3	R-11
TYPICAL ROOF CONNECTION SECTIONS (ROOF TO WALL)		N.T.S.	

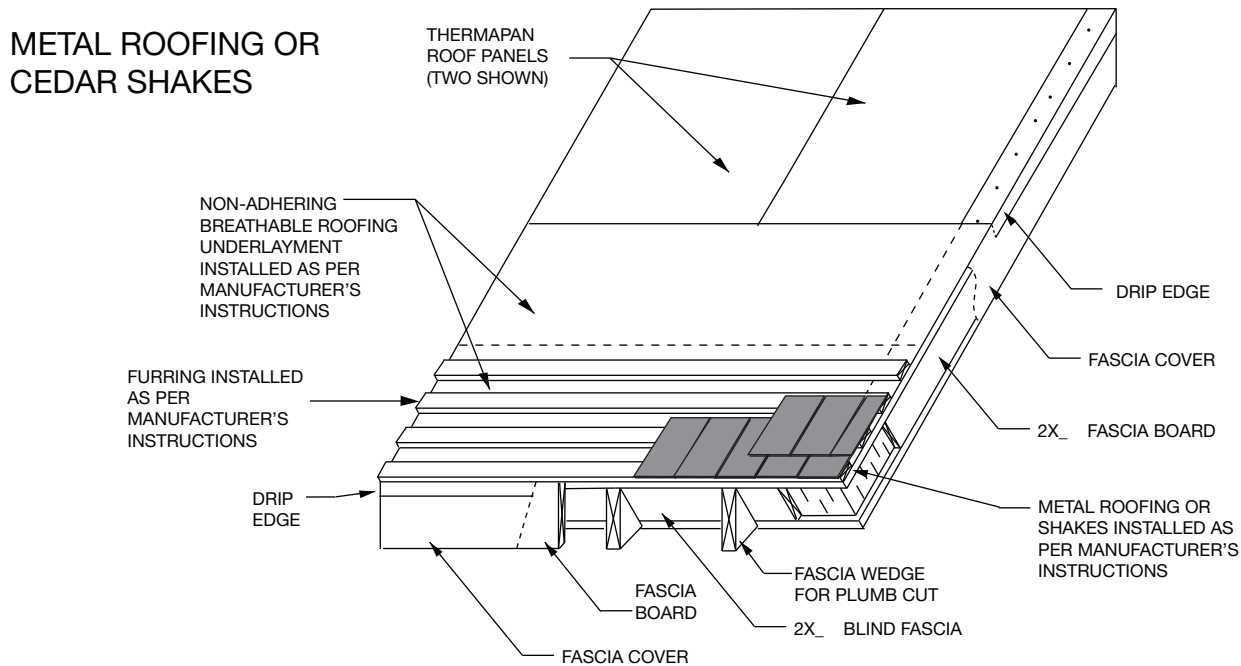
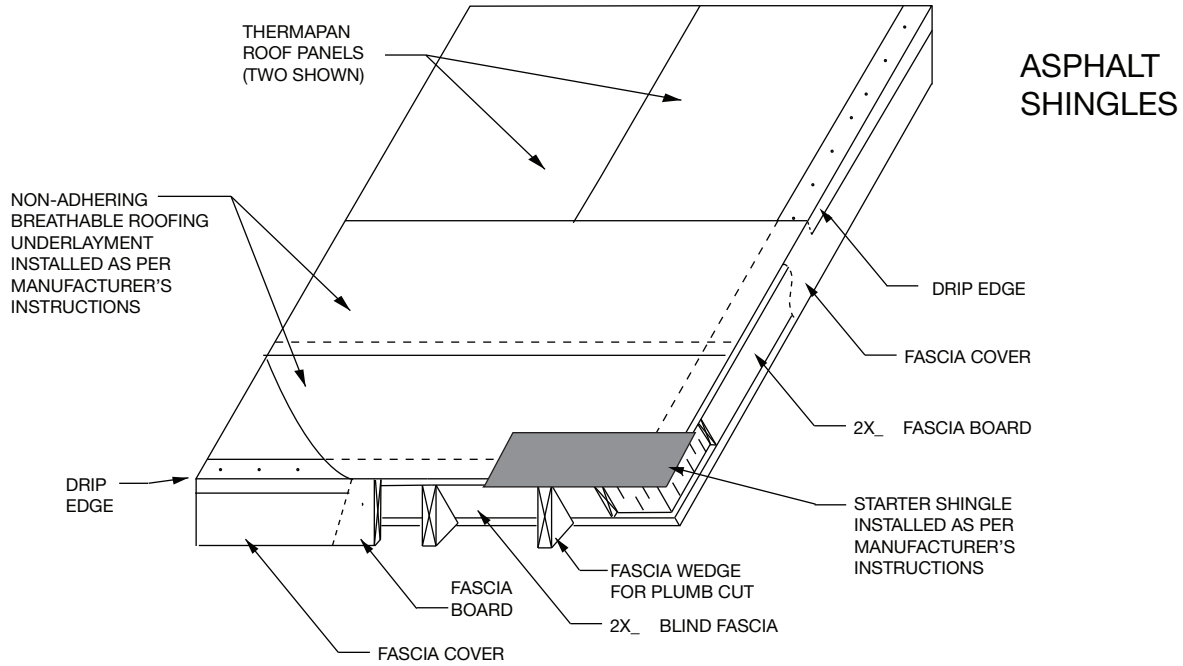

NOTE: VENTILATION OF SIP ROOF NOT REQUIRED.



www.thermapan.com
1-877-443-WALL (9255)

TITLE		PROJECT	
<p style="text-align: center;">ROOFING APPLIED TO SLOPED SIPS</p>			
		REFERENCE	SCALE
DATE	REVISION	N.T.S.	
AUGUST 2017	2	DWG. No.	R-12

**MEMBRANE
(EPDM, PVC, TPO, ETC.)**

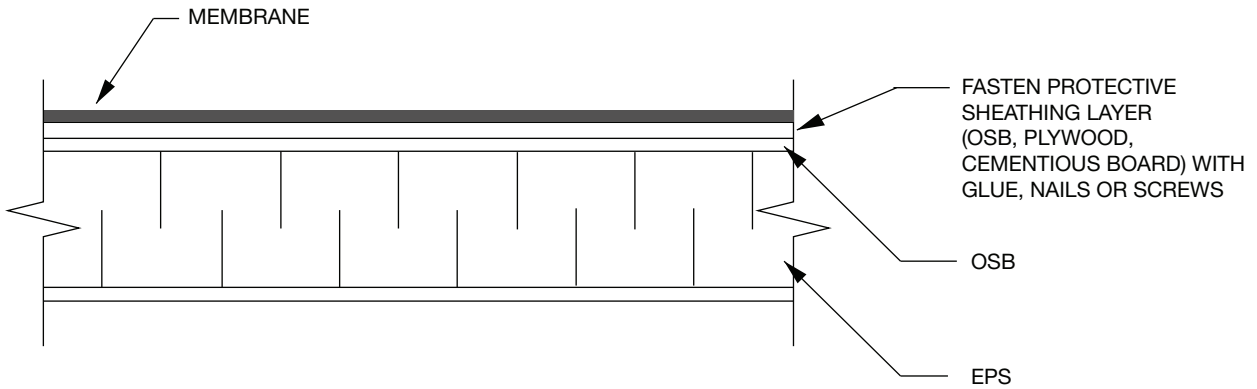

NOTES:

- SIP SURFACE TO BE DRY AND FREE OF MOISTURE
- PROTECTIVE SHEATHING LAYER TO BE DRY AND FREE OF MOISTURE
- SOLVENT BASED ADHESIVES ARE NOT PERMITTED
- INSTALL MEMBRANE ACCORDING TO MEMBRANE MANUFACTURER'S DETAILS AND IN CONFORMANCE TO REQUIREMENTS OF LOCAL BUILDING CODE

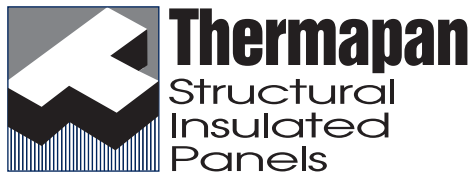

www.thermapan.com
1-877-443-WALL (9255)

TITLE		PROJECT	
REFERENCE		SCALE	
		N.T.S.	
DATE		REVISION	DWG. No.
NOVEMBER 2022			R-13

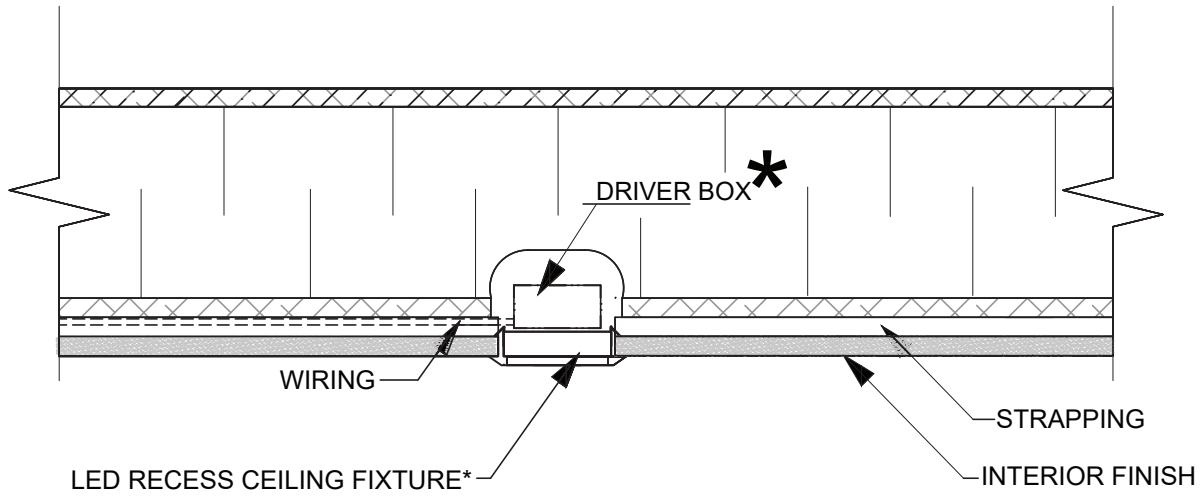

***FIXTURE SPECIFICATIONS**

FIXTURE TO HAVE AMBIENT OPERATING TEMPERATURE +140F(+40C) MAXIMUM
 INSTALL AS PER MANUFACTURERS SPECIFICATIONS

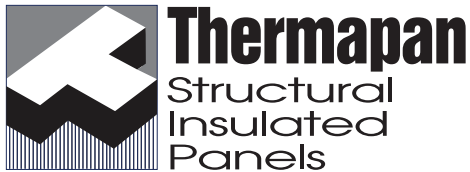

www.thermapan.com
 1-877-443-WALL (9255)

TITLE		LED POT LIGHT INSTALLATION IN CEILING SIPS		PROJECT
REFERENCE		SCALE		
DATE		N.T.S.		
JANUARY 2017		REVISION	DWG. No.	R-14

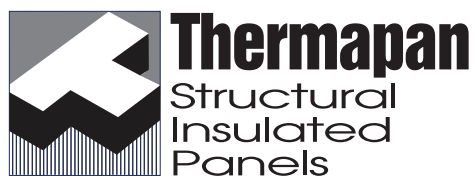
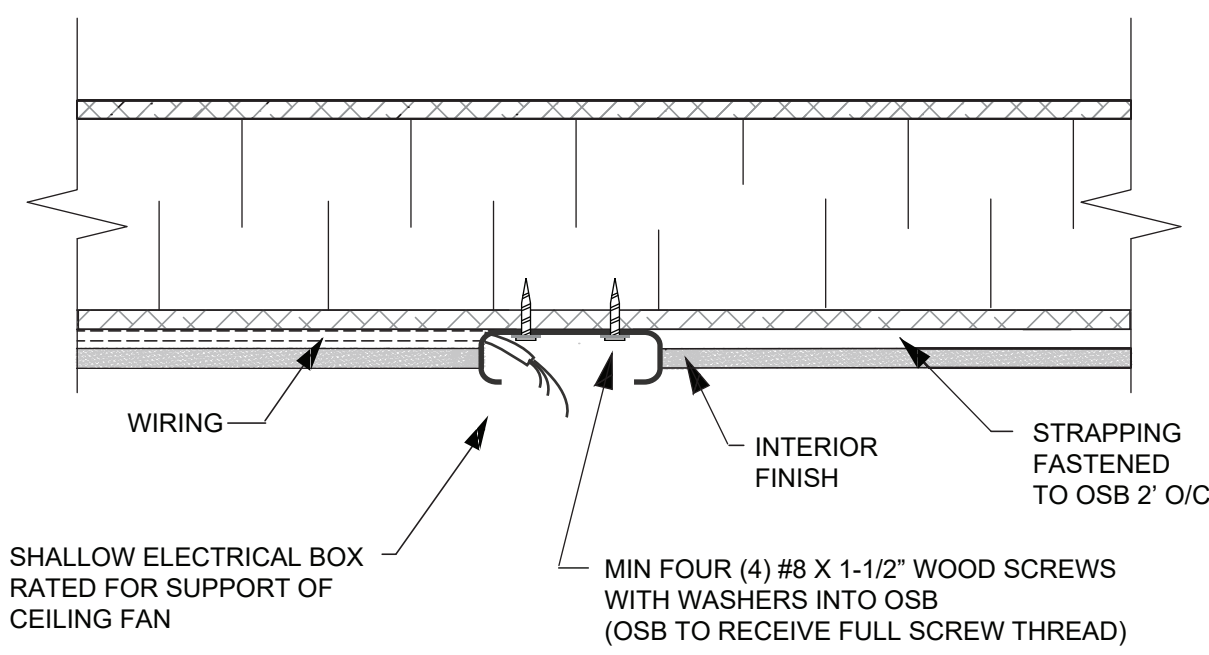

www.thermapan.com
1-877-443-WALL (9255)

TITLE		PROJECT	
CEILING FAN ATTACHMENT			
REFERENCE	SCALE	N.T.S.	
DATE	REVISION		
FEBRUARY 2018		R-15	

METAL ROOFING OR CEDAR SHAKES

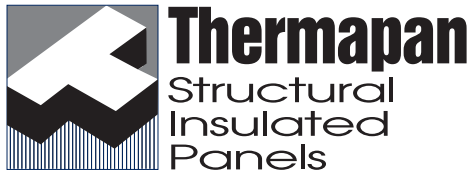
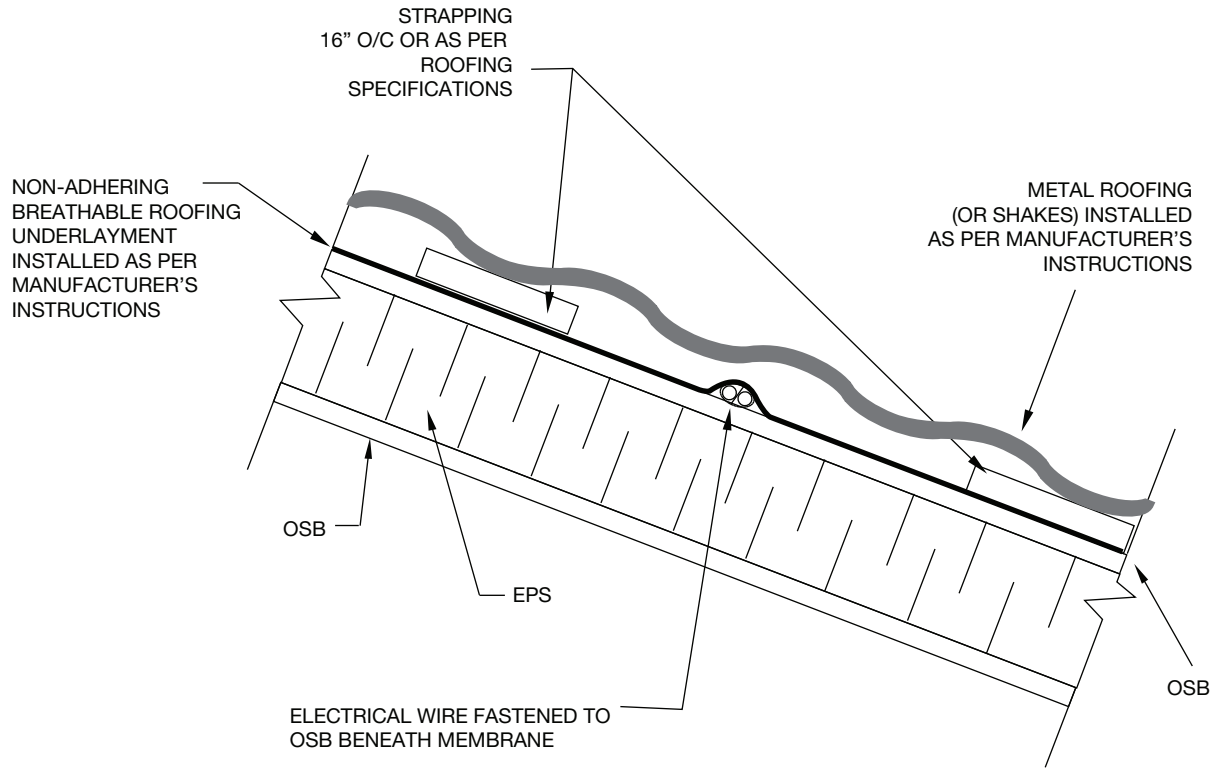

www.thermapan.com
1-877-443-WALL (9255)

TITLE		PROJECT	
ELECTRICAL WIRE FASTENED TO ROOF SIP		PROJECT	
REFERENCE	SCALE	N.T.S.	
DATE	REVISION	DWG. No.	
MARCH 2021		R-16	

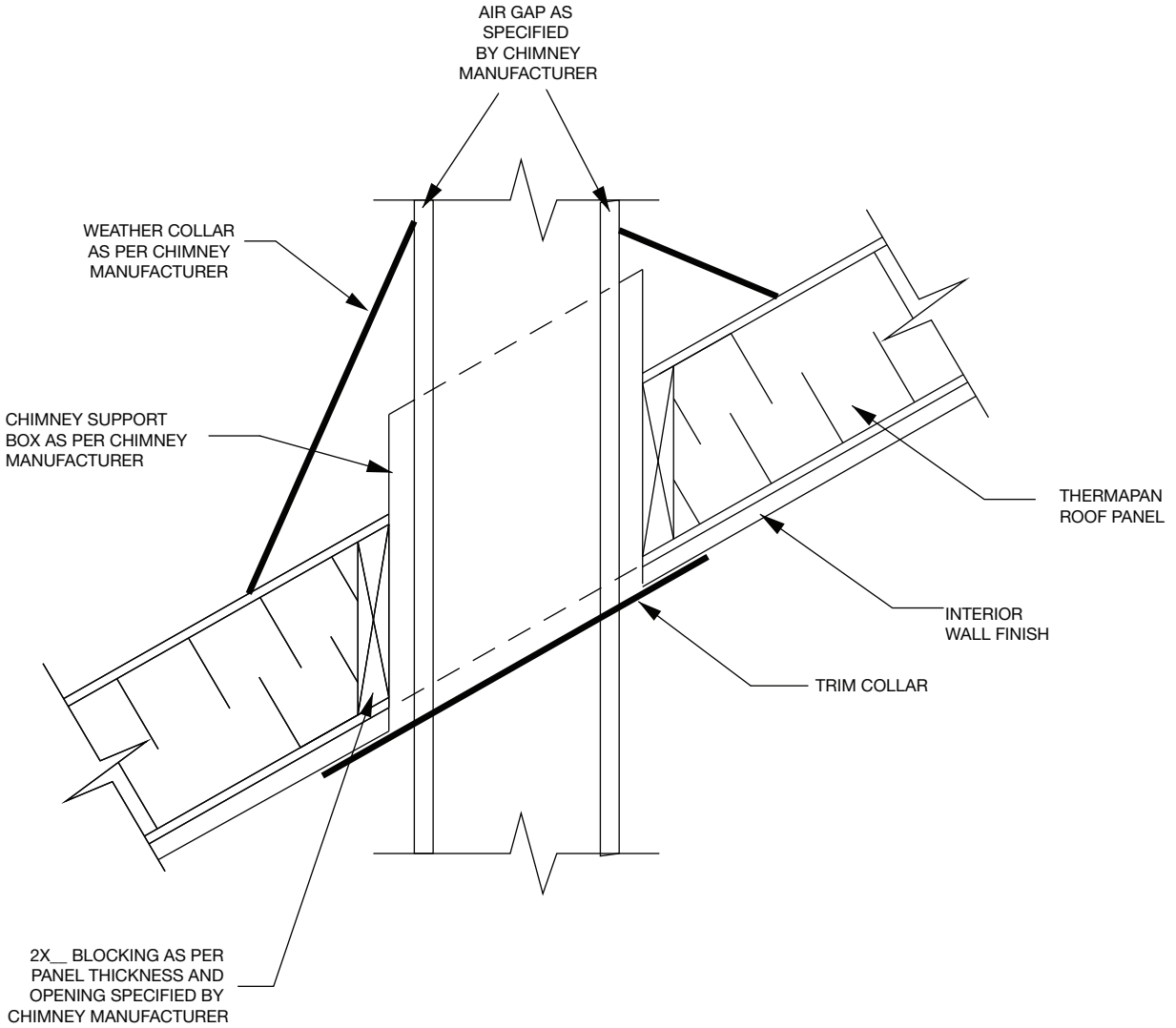

NOTE: ABOVE DETAILS ARE TYPICAL REQUIREMENTS TO INSTALL A PREFABRICATED METAL CHIMNEY IN A THERMAPAN STRUCTURAL INSULATED PANEL. THE CHIMNEY INSTALLATION MUST COMPLY WITH THE CHIMNEY MANUFACTURERS'S SPECIFICATION AND THE APPLICABLE BUILDING CODE.

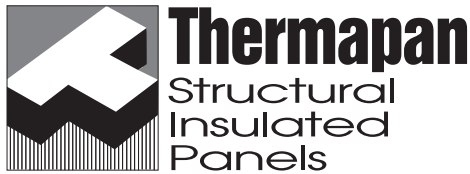

www.thermapan.com
1-877-443-WALL (9255)

TITLE		PROJECT	
PRE-FABRICATED METAL CHIMNEY – ROOF INSTALLATION			
REFERENCE	SCALE		
	N.T.S.		
DATE	REVISION	DWG. No.	
FEBRUARY 2019		R-17	

TYPICAL SIP ROOF SECTION

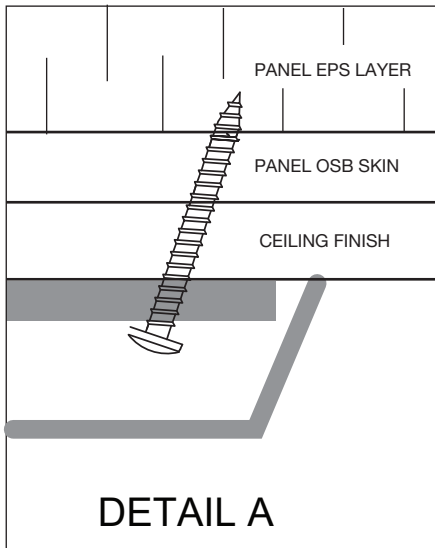
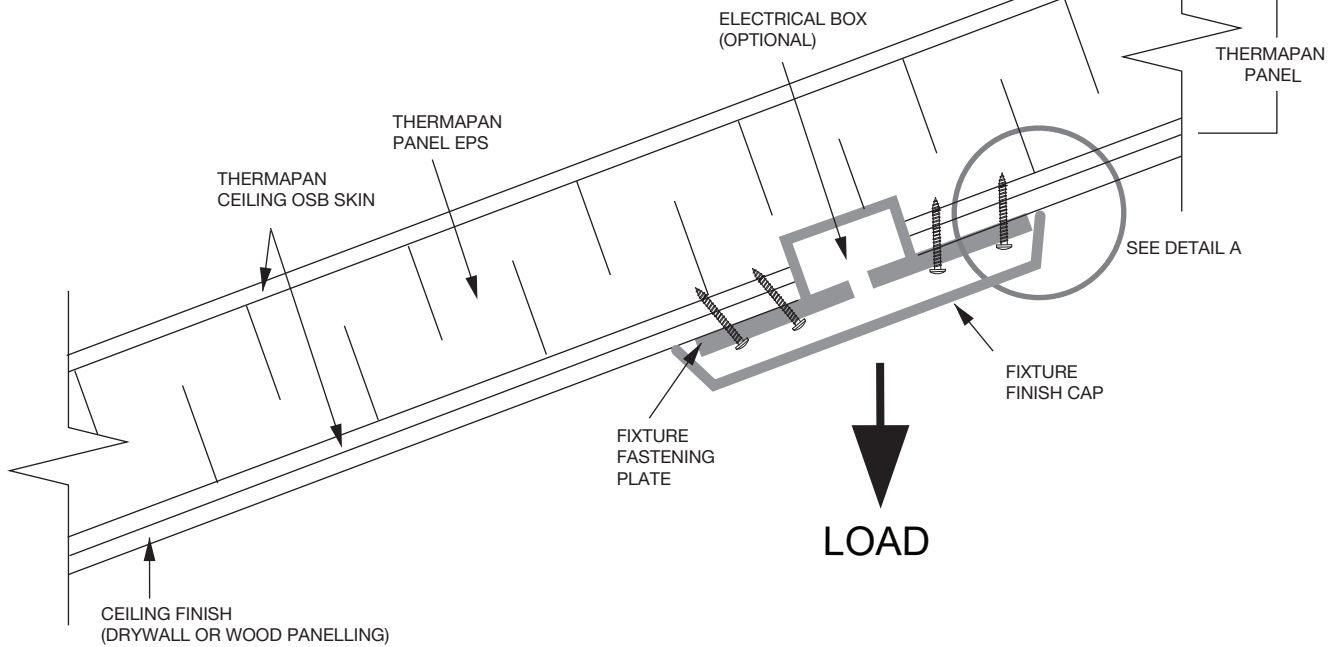

CEILING LOAD RESISTANCE CAN BE ACHIEVED WITH NUMBER 10 SHEET METAL SCREWS INSTALLED TO A SIP CEILING FINISH AS DETAILED OR TO THE SIP SKIN DIRECTLY.

EACH SCREW CAN RESIST A PULL OUT OF 90 POUNDS IN 7/16" OSB. CONTRACTOR TO CONFIRM LOAD TO BE SECURED AND NUMBER OF FASTENERS REQUIRED. MINIMUM 4 SCREWS PER FIXTURES. FULL THICKNESS OF OSB TO RECEIVE SCREW THREAD ON ANGLE AS DETAILED

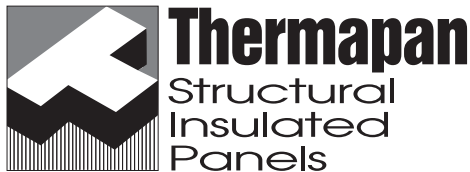

www.thermapan.com
1-877-443-WALL (9255)

TITLE		PROJECT	
SCREW FASTENER DETAIL FOR SECURING LOAD TO THERMAPAN CEILING PANEL			
REFERENCE	SCALE		
	N.T.S.		
DATE	REVISION	DWG. No.	
FEBRUARY 2020		R-18	

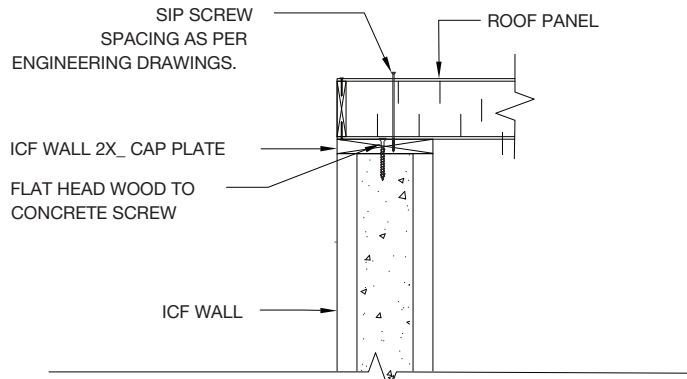

**ROOF SIP PANEL TO ICF CONNECTION
(CONCRETE SCREW OPTION)**

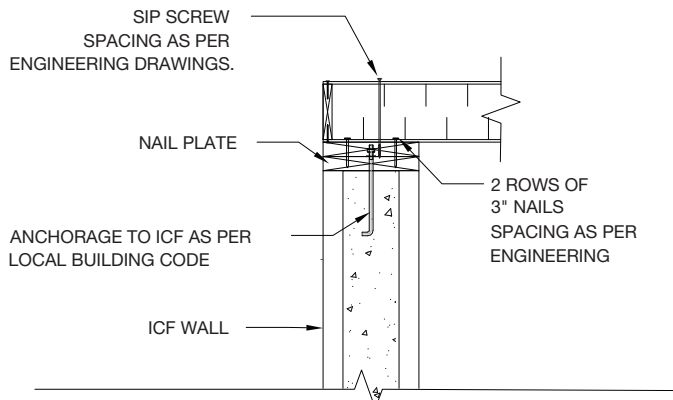

**ROOF SIP PANEL TO ICF CONNECTION
(ANCHORAGE OPTION)**



www.thermapan.com
1-877-443-WALL (9255)

TITLE		PROJECT	
ROOF SIP TO ICF CONNECTION DETAIL			
REFERENCE	SCALE		
	N.T.S.		
DATE	REVISION	DWG. No.	
MARCH 2024		R-19	

UNFINISHED EAVE DETAIL FOR LEVEL SOFFIT

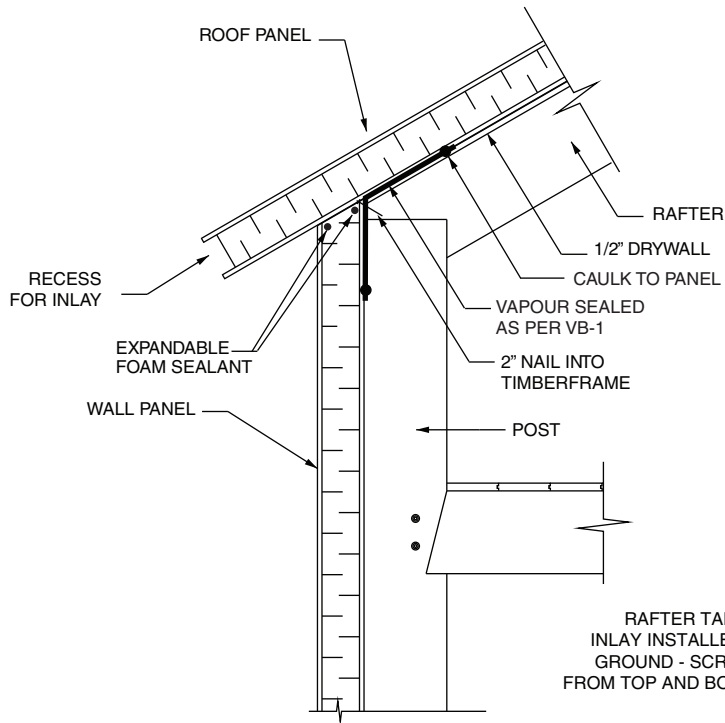

FINISHED EAVE DETAIL WITH LEVEL SOFFIT

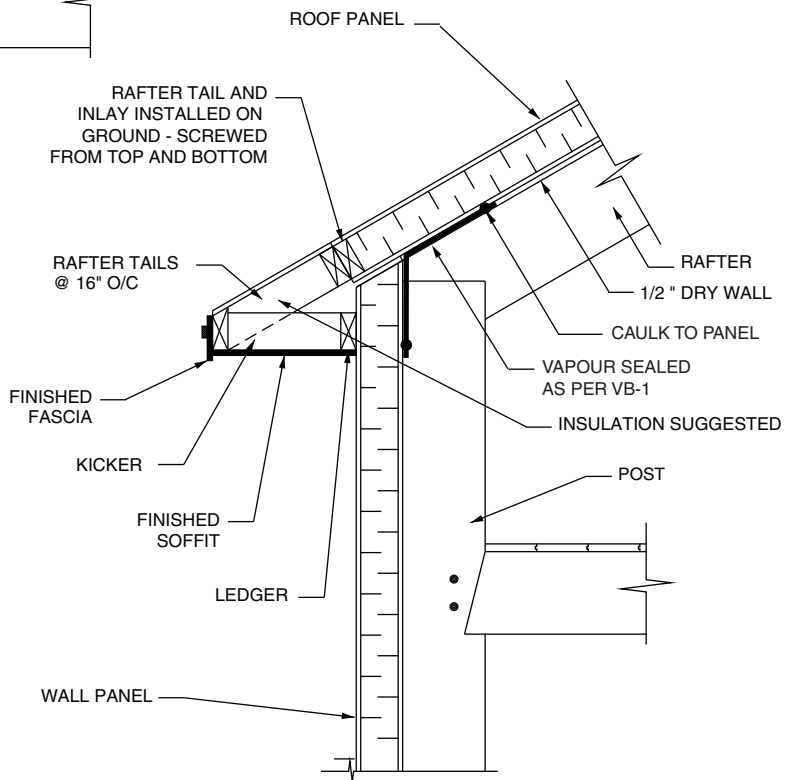

NOTE: REFER TO AIR BARRIER (AB-2) AND VAPOUR BARRIER (VB-1) DETAILS FOR SEALING SIP CONNECTIONS.

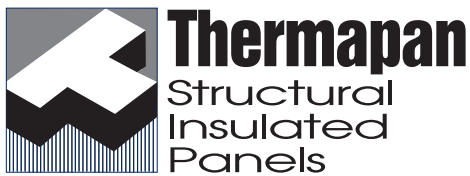

www.thermapan.com
1-877-443-WALL (9255)

TITLE		PROJECT	
ROOF OVERHANG EAVE DETAILS (TIMBERFRAME)			
REFERENCE	SCALE		
8020	N.T.S.		
DATE	REVISION	DWG. No.	
FEBRUARY 2012	3	R-TF-1	

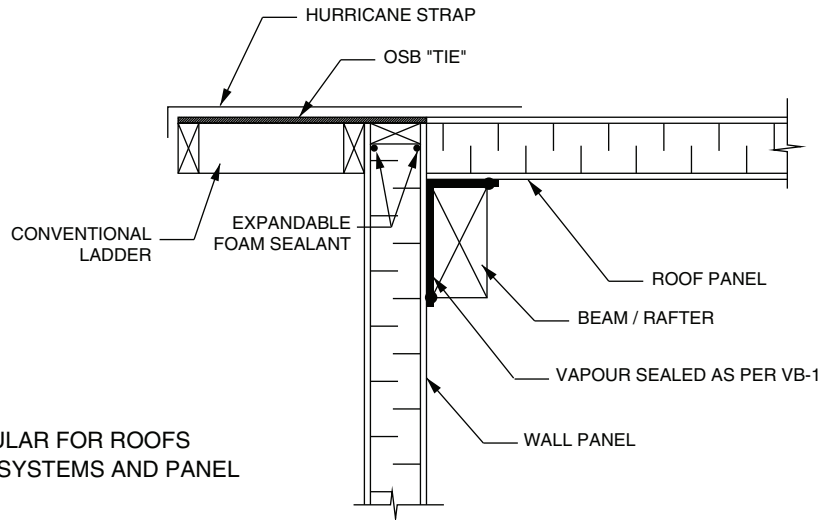

BUILT OUT OPTION POPULAR FOR ROOFS WITH COMMON RAFTER SYSTEMS AND PANEL ORIENTED VERTICALLY

NOTE: SCREW AND GLUE LADDER TO WALL PANEL

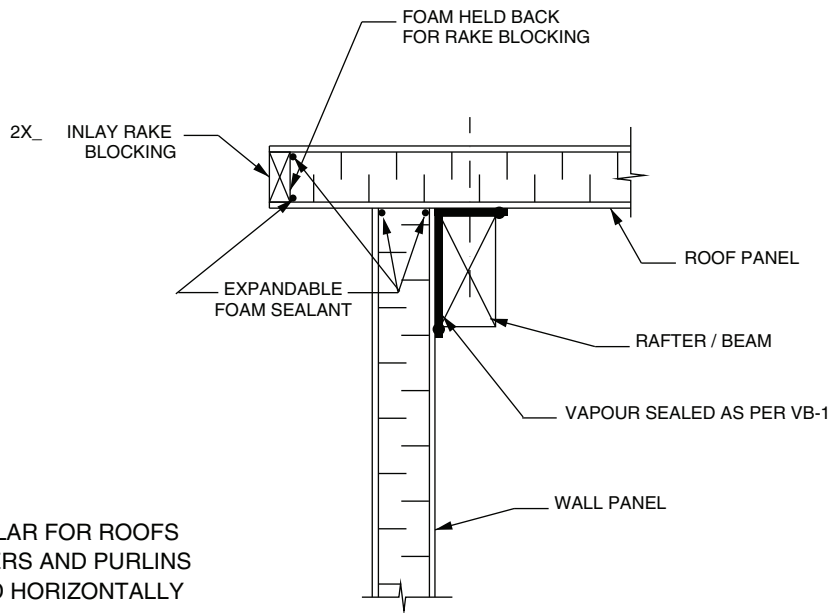

RUN-BY OPTION, POPULAR FOR ROOFS WITH PRINCIPAL RAFTERS AND PURLINS AND PANELS ORIENTED HORIZONTALLY

NOTE: REFER TO AIR BARRIER (AB-2) AND VAPOUR BARRIER (VB-1) DETAILS FOR SEALING SIP CONNECTIONS.

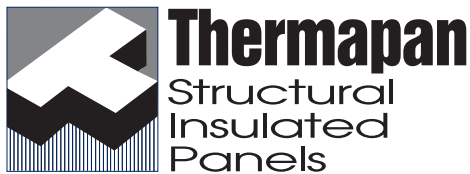

www.thermapan.com
1-877-443-WALL (9255)

TITLE		PROJECT	
ROOF OVERHANG & RAKE (TIMBERFRAME)			
REFERENCE	SCALE		
8020	N.T.S.		
DATE	REVISION	DWG. No.	
MAY 2009	2	R-TF-2	