

The better way to build™



Installation Manual EXTERIOR WALL SIPs



Thermapan
Structural
Insulated
Panels

EXTERIOR WALL SIPs Installation Manual

Table of Contents

Topics

General Requirements	3
Materials	3
Electrical Wiring	3
Interior Finish	4
Exterior Cladding	4
Materials Estimating	5

Details

Air Barrier Details for Air Barrier Sealants	AB-1
Air Barrier Details for Sealing SIP Connections	AB-2
Vapour Barrier Details for Vapour Sealing SIP Connections.	VB-1
Foam Core (SIP) Spline Detail.	W-1
Wood Stud Spline Joint Detail	W-2
Typical Wall Section	W-3
Floor-to-Wall Connection Detail	W-4
Sill Plate Detail	W-5
Wall Butt Corner Connection Detail	W-6
Window Cut-Out (Non-Load Bearing Wall).	W-7
Panel Lintel/Header Details & Bearing Conditions 1-4.	W-8
Lintel Detail	W-9
Point Load Detail.	W-10
Knee Wall Detail	W-11
Door & Window Rough Openings	W-12
Wood Ledger Attached to SIP Wall Panel.	W-13
Kicker Truss Detail	W-14
Vertical Electrical Chase	W-15
Exterior Wire Fastened to SIP Exterior	W-16
Exterior Wall Cladding - Brick & Cultured Stone.	W-17
Exterior Wall Cladding - Stucco (Traditional & EIFS).	W-18
Exterior Wall Cladding - Siding	W-19
Interior Wall Finish - Gypsum	W-20: TBD
Pre-Fabricated Metal Chimney Installation in Wall.	W-21
Screw Fastening Detail for Securing Shelving to Panel	W-22
Wall SIP to ICF Connection	W-23
SIP Wall to Concrete Knee Wall Connection	W-24
Wall SIP to Steel Column Connection.	W-25
60 Min. Partywall Single Wall STC Rating 50	PW-1
Partywall Electrical Detail (60 Min. Single Wall)	PW-2
60 Min. Partywall Double Wall STC Rating 50	PW-3
Partywall Electrical Detail (60 Min. Double Wall)	PW-4
Vertical Panel Connections Spline & Corner (Timberframe)	W-TF-1
Horizontal Connections at Beams (Timberframe)	W-TF-2
Foundation Details Deck Options (Timberframe)	W-TF-3

EXTERIOR WALL SIPs Installation Manual

1. General Requirements

1.1 Scope

The basic design and construction requirements for the Thermapan Structural Insulated Panel (SIP) wall system is set forth in this specification. Criteria for materials, environmental control, design loads, and structural design are included. Where requirements are based on internationally recognized standards and specifications, these standards and specifications are referenced without elaboration.

Installers shall reference engineering design package for fastening arrangements.

2. Materials

- 2.1** The Thermapan Wall SIP is composed of an expanded polystyrene (EPS) foam core laminated between two layers of oriented strand board (OSB) with a structural adhesive. (See Detail W-1)
- 2.2** Framing Lumber shall be DOC PS 20 or NLGA No.2 or better.
- 2.3** Wire nails, ring nails, spikes and staples shall conform to CSA B111 or ANSI/ASME B11.1.
- 2.4** Wood screws shall conform to ANSI/ASME B18.6.1..
- 2.5** SIP screws shall conform to ICC-AC233.
- 2.6** Caulking Compounds shall conform to CAN/CGSB 19.13 or ASTM C 920.
- 2.7** Polyethylene Sheeting shall conform to CAN/CGSB-37.2, CAN/CGSB-37.16, or ASTM D 4397.
- 2.8** Low expansion foam seal shall conform to AAMA 812-04.
- 2.9** Structural adhesive shall conform to CAN/CGSB 71GP26, APA AFG-01 or ASTM D3498.

3. Electrical Wiring

- 3.1** All wire chases to be vertically cut into the wall SIP at a minimum depth of 2". See Detail W-14.

4. Interior Finish

- 4.1** The interior of the wall SIP can be finished with any of the common required building code materials. It is recommended that the SIP joints and connections be sealed as per Details AB-1 and AB-2.

5. Exterior Cladding

- 5.1** A weather barrier is to be installed over the exterior OSB of the SIP and under the cladding and/or furring. Refer to Details W-15 and W-16 and your local building code for compliant weather barrier materials.

MATERIALS ESTIMATING

Above Grade Exterior Walls Estimation Only

Lumber Requirements:

- SPF Single top and bottom plate
- OSB 1-1/8" (28mm) Cap plate – 12 ft (3658mm) lengths

- Every panel requires a spline
- Every corner requires 2 SPF studs
- Windows and doors require jack studs as per OBC and cripples

Caulking and Sealant Requirements:

- Every 1200 sqft (111 m²) of SIP equals 1 case of Expandable Foam
- Every 2000 sqft (185 m²) of SIP requires 1 case of Sealant

Fasteners:

- Recommend 2" (50mm) Ring nail or 2" (50mm) screws for connection to panel

- 3.0 times the square footage of SIPs

AIR BARRIER

RECOMMENDED DETAILS FOR AIR BARRIER SEALANTS

All sealants, FOAM (A) or CAULKING (B), should be applied onto the SIP in a continuous rectangular pattern along the outer most edge of the area to be sealed.

(A) A low expansion EXPANDABLE FOAM SEALANT should conform to the AAMA 812-04 standard. Apply a 1/2 inch or a 12.5 mm diameter of a *continuous* bead of expandable foam sealant onto the SIP:

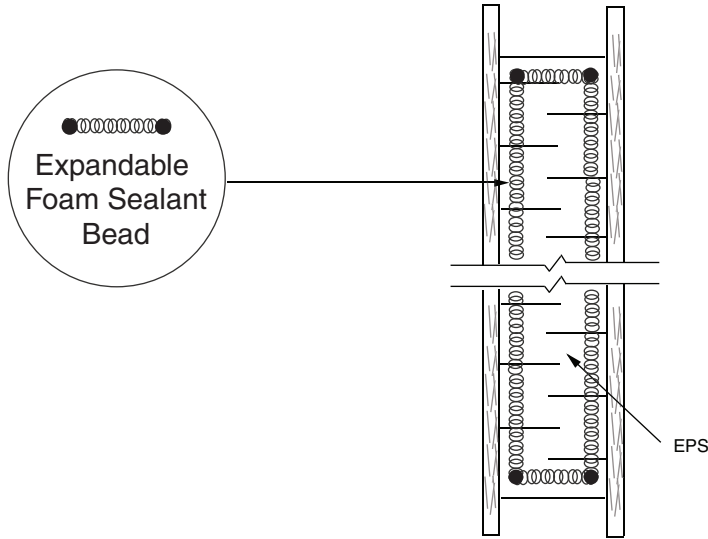

(B) A CAULKING SEALANT should conform to ASTM C920-02 and/or CAN/CGSB 19.13-M. Apply a 3/8 inch or a 10 mm diameter *continuous* bead of caulking onto the lumber spline:

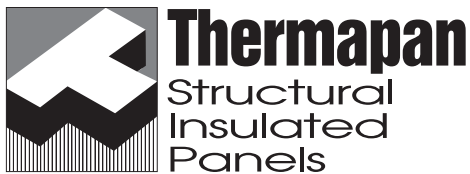
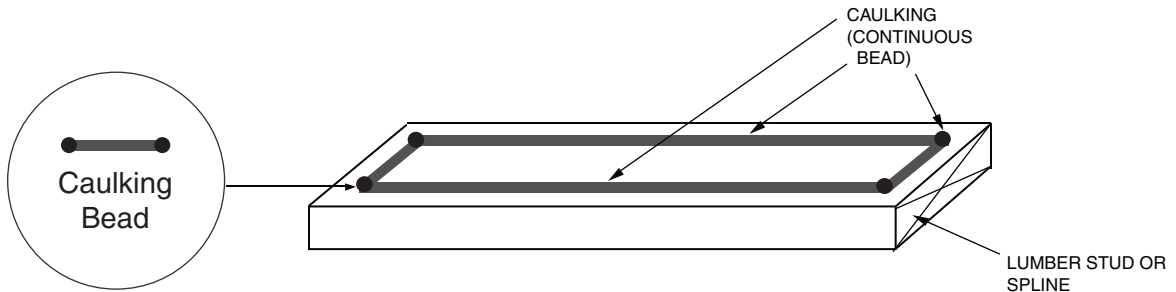

www.thermapan.com
1-877-443-WALL (9255)

	TITLE	PROJECT	
	AIR BARRIER DETAILS FOR AIR BARRIER SEALANTS		
	REFERENCE	SCALE	
		N.T.S.	
	DATE	REVISION	DWG. No.
	NOVEMBER 2010	1	AB-1

AIR BARRIER

RECOMMENDED DETAILS FOR SEALING SIP CONNECTIONS

(1) Foam to Foam: Use a low expansion foam sealant.

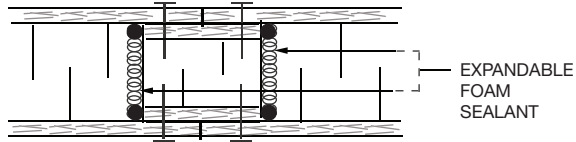

SIP SPLINE JOINT

(2) Foam to Wood: Use a low expansion foam sealant.

PLATES SECTION

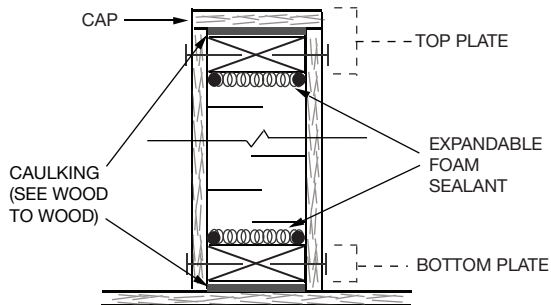

LUMBER SPLINES

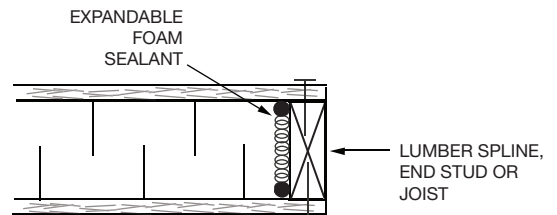

(3) Wood to Wood: Use caulking and a low expansion foam sealant.

CORNER DETAIL PLAN

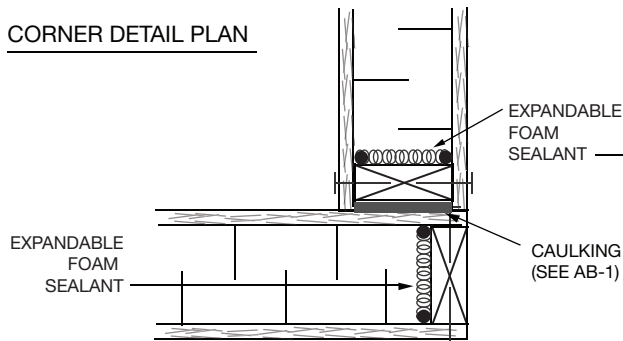

LUMBER SPLINE

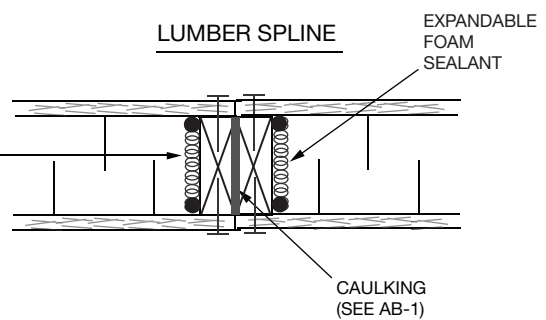

www.thermapan.com
1-877-443-WALL (9255)

TITLE		PROJECT	
AIR BARRIER DETAILS FOR SEALING SIP CONNECTIONS			
REFERENCE	SCALE		
	N.T.S.		
DATE	REVISION	DWG. No.	
MAY 2020	1	AB-2	

VAPOUR BARRIER

RECOMMENDED DETAILS FOR VAPOUR SEALING SIP CONNECTIONS

The function of a vapour barrier is to control the entry of water vapour into the building assembly. Vapour barriers should not be confused with an air barrier.

All SIP seams and connections must be VAPOUR SEALED from the INTERIOR.

These are recommended vapour barrier methods:

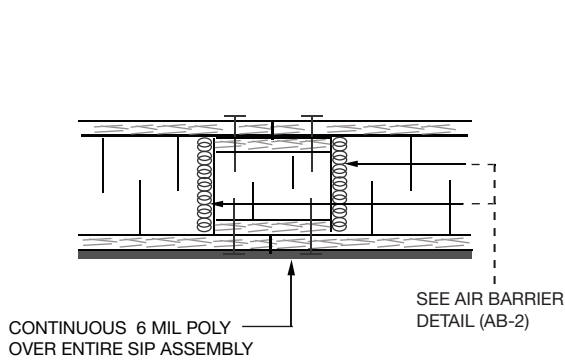

CONTINUOUS 6 MIL POLY
RECOMMENDED

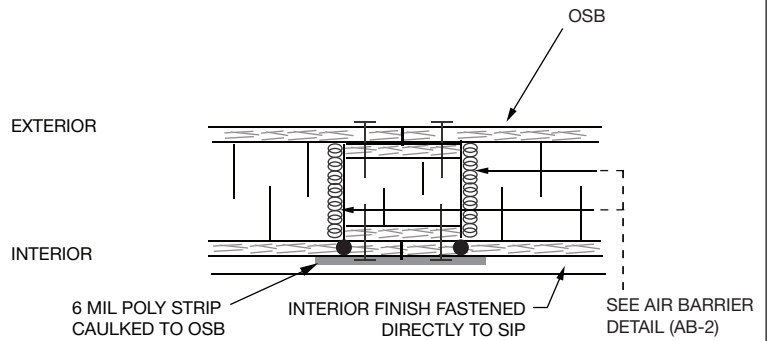

6 MIL POLY STRIPS & CAULKING

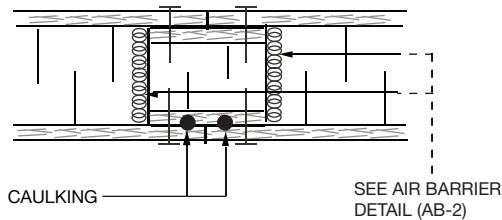

CAULKING

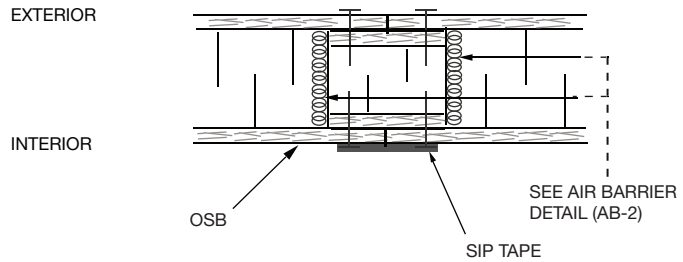

SIP TAPE

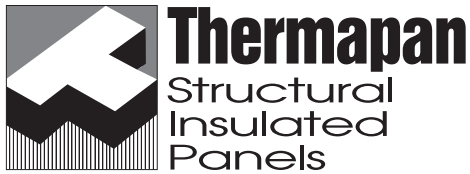

www.thermapan.com
1-877-443-WALL (9255)

TITLE		PROJECT	
VAPOUR BARRIER DETAILS FOR VAPOUR SEALING SIP CONNECTIONS			
REFERENCE	SCALE		
	N.T.S.		
DATE	REVISION	DWG. No.	
MAY 2020	2	VB-1	

**ISOMETRIC
VIEW**

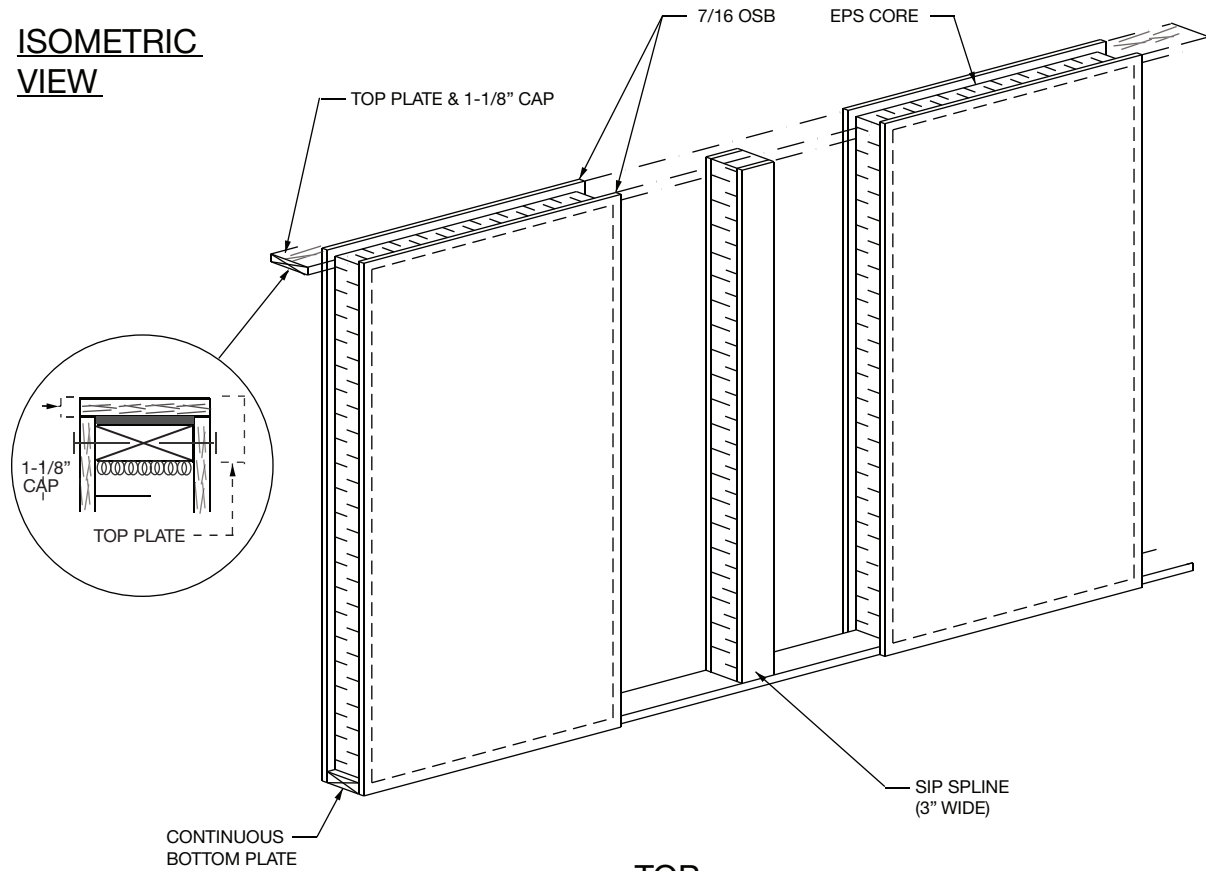

**TOP
VIEW**

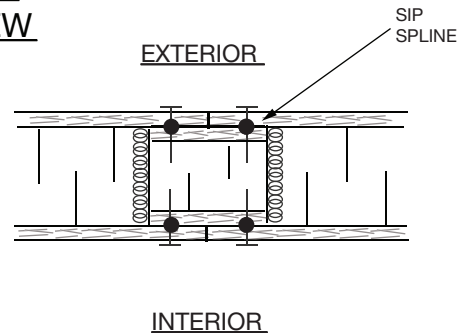

NOTE: REFER TO AIR BARRIER (AB-2) DETAIL FOR SEALING SIP CONNECTIONS.

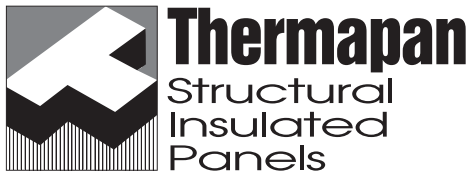

www.thermapan.com
1-877-443-WALL (9255)

TITLE		PROJECT	
FOAM CORE (SIP) SPLINE DETAIL			
REFERENCE	SCALE	N.T.S.	
DATE	REVISION		
APRIL 2014	6	DWG. No.	W-1

**ISOMETRIC
VIEW**

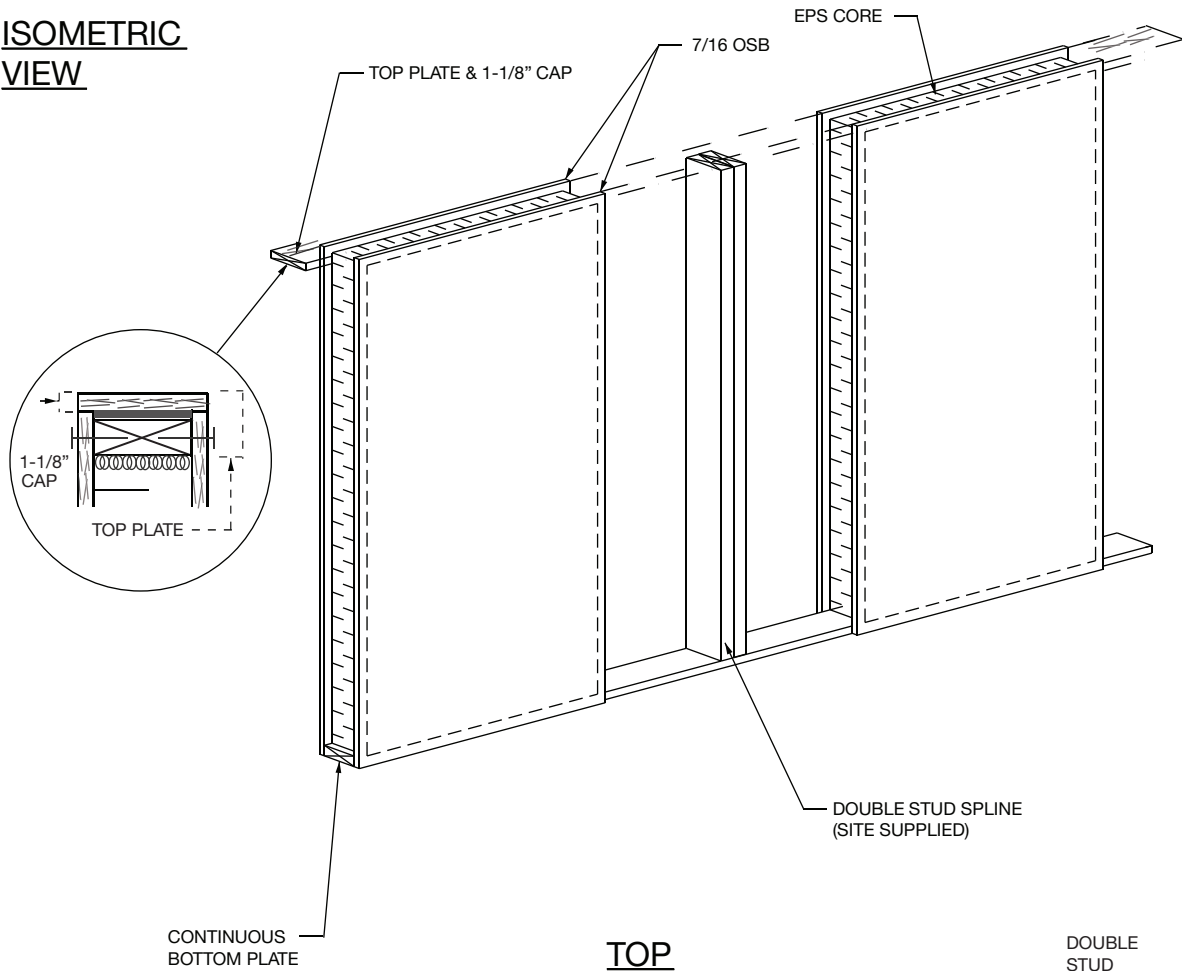

**TOP
VIEW**

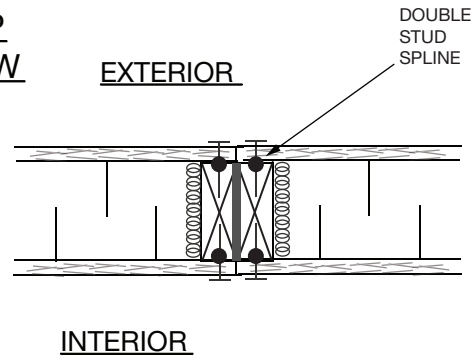

NOTE: REFER TO AIR BARRIER (AB-2) DETAIL FOR SEALING SIP CONNECTIONS.



Thermapan
Structural
Insulated
Panels

www.thermapan.com
1-877-443-WALL (9255)

TITLE		PROJECT	
WOOD STUD SPLINE JOINT DETAIL			
REFERENCE	SCALE		
	N.T.S.		
DATE	REVISION	DWG. No.	
APRIL 2014	6	W-2	

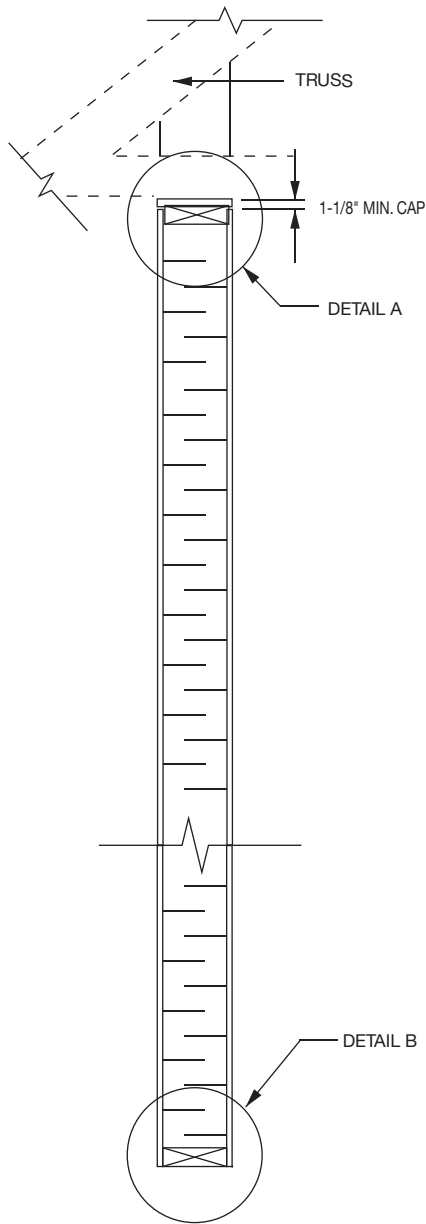

SECTION

DETAIL A

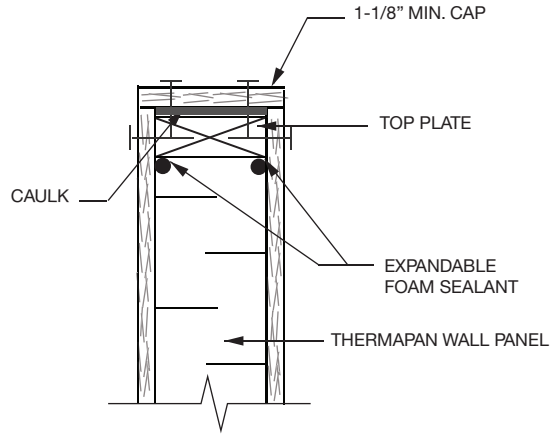

DETAIL B

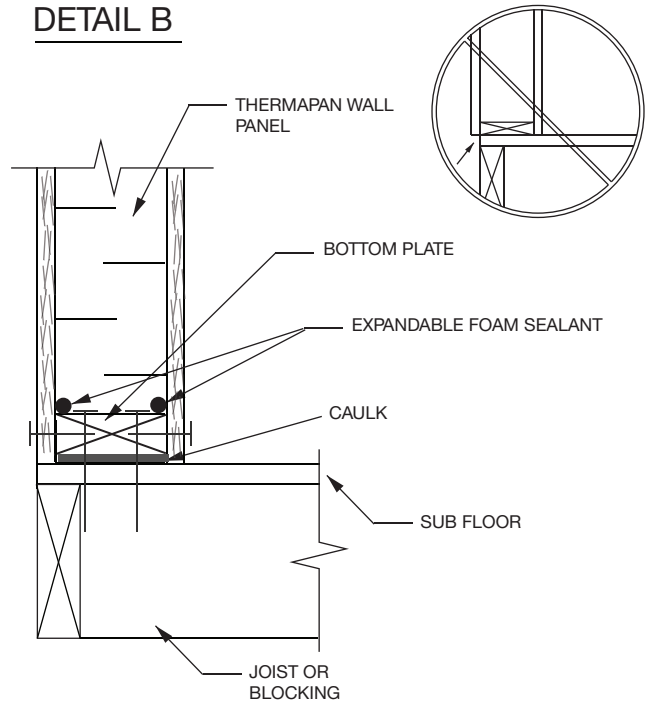

NOTE: REFER TO AIR BARRIER (AB-2) DETAIL FOR SEALING SIP CONNECTIONS.

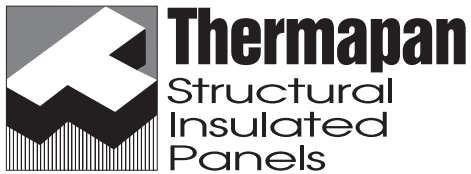

www.thermapan.com
1-877-443-WALL (9255)

TITLE		PROJECT	
TYPICAL WALL SECTION			
REFERENCE	SCALE		
	N.T.S.		
DATE	REVISION	DWG. No.	
APRIL 2014	6	W-3	

PLATFORM FRAMING

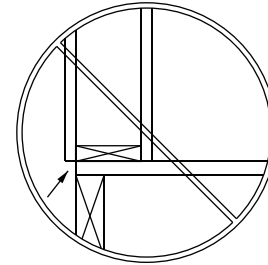
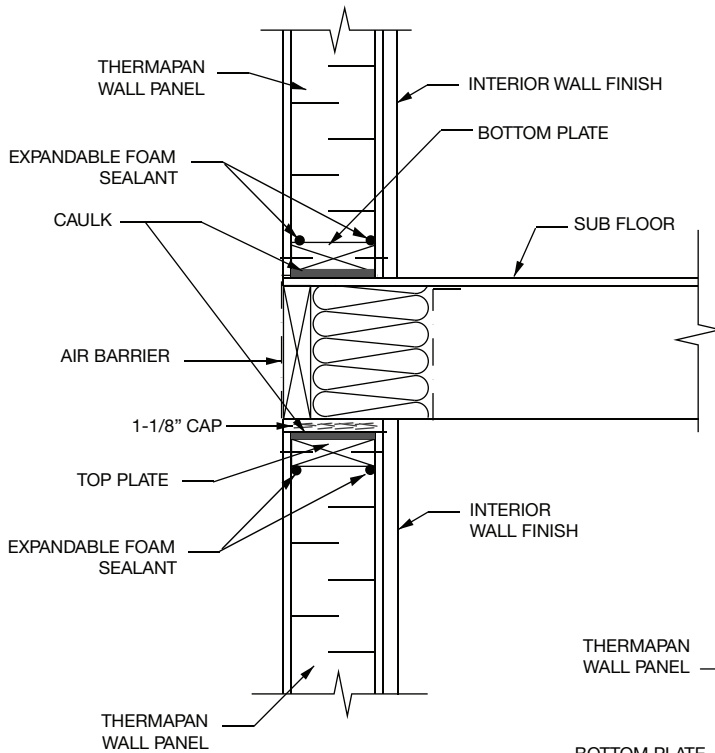

SUSPENDED FLOOR DETAIL

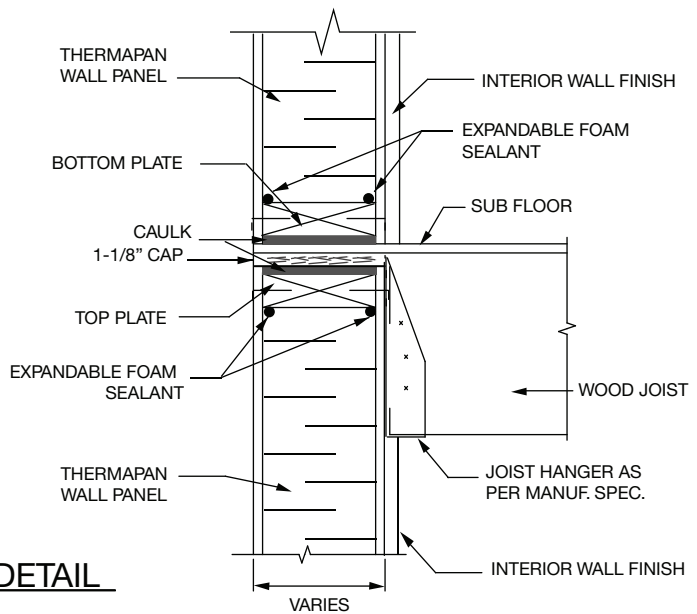

NOTE: REFER TO AIR BARRIER (AB-2) DETAIL FOR SEALING SIP CONNECTIONS.

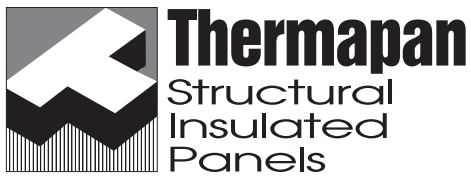

www.thermapan.com
1-877-443-WALL (9255)

TITLE		PROJECT	
FLOOR-TO-WALL CONNECTION DETAIL			
REFERENCE	SCALE		
	N.T.S.		
DATE	REVISION	DWG. No.	
JUNE 2016	6	W-4	

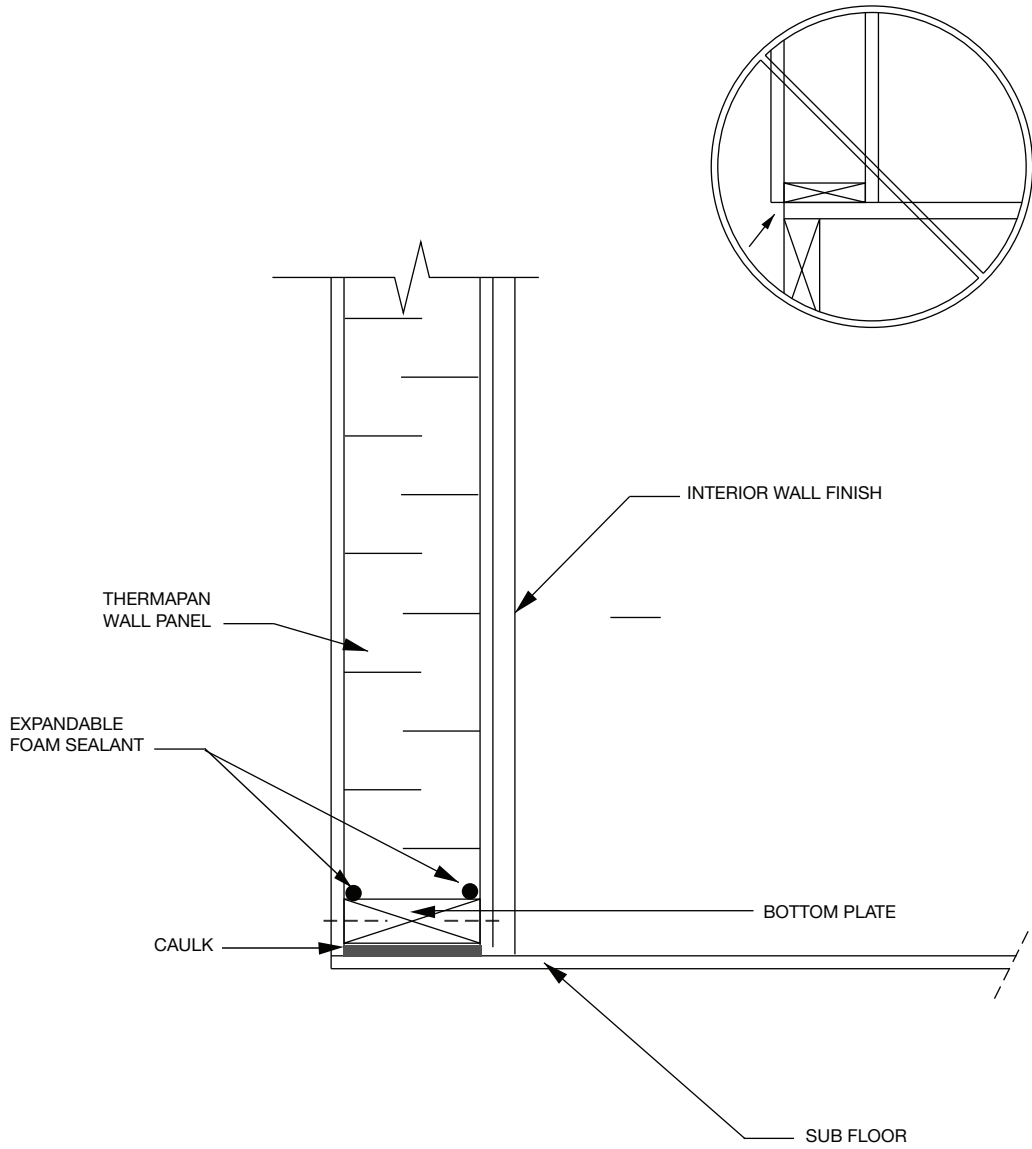

NOTE: REFER TO AIR BARRIER (AB-2) DETAIL FOR SEALING SIP CONNECTIONS.

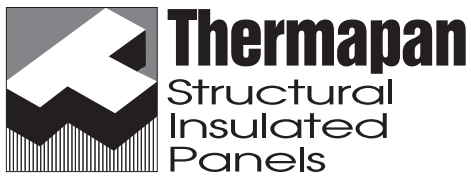

www.thermapan.com
1-877-443-WALL (9255)

TITLE		PROJECT	
SILL PLATE DETAIL			
REFERENCE	SCALE		
	N.T.S.		
DATE	REVISION	DWG. No.	
JUNE 2016	5	W-5	

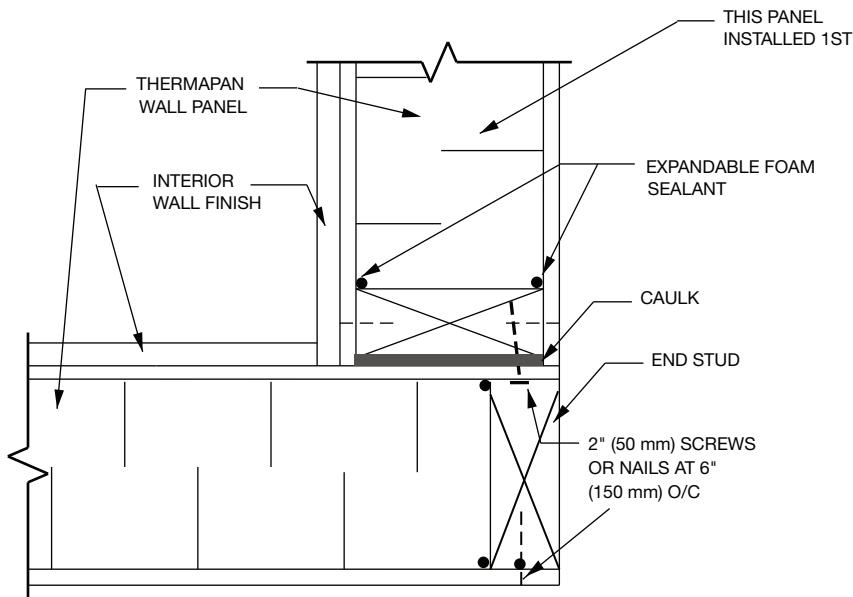

CORNER DETAIL
(FOR BRICK VENEER OR SIDING)

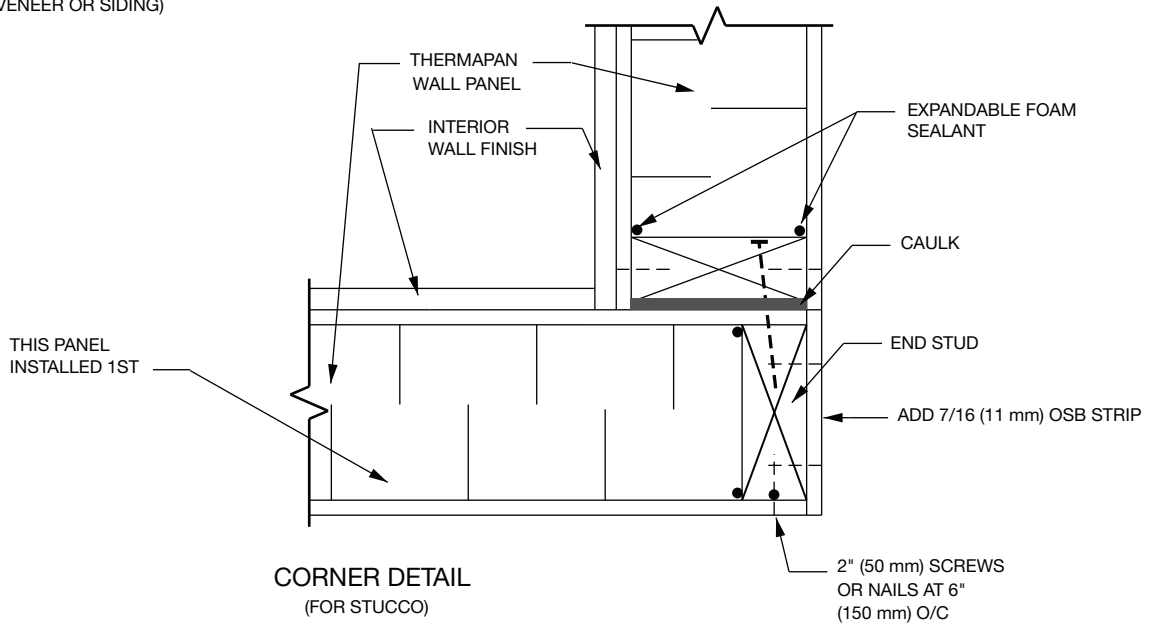

CORNER DETAIL
(FOR STUCCO)

NOTE: REFER TO AIR BARRIER (AB-2) DETAIL FOR SEALING SIP CONNECTIONS.

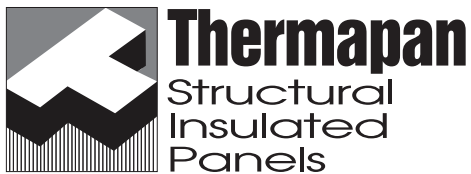

www.thermapan.com
1-877-443-WALL (9255)

TITLE		PROJECT	
WALL BUTT CORNER CONNECTION DETAIL			
REFERENCE	SCALE	N.T.S.	
DATE	REVISION	DWG. No.	
JUNE 2016	5	W-6	

- ① NON-LOAD BEARING WALL:
MAX. UNFACTORED LIVE LOAD = 160 lb./ft. (2.4 kN/m)
MAX. UNFACTORED DEAD LOAD = 50 lb./ft. (0.75 kN/m)

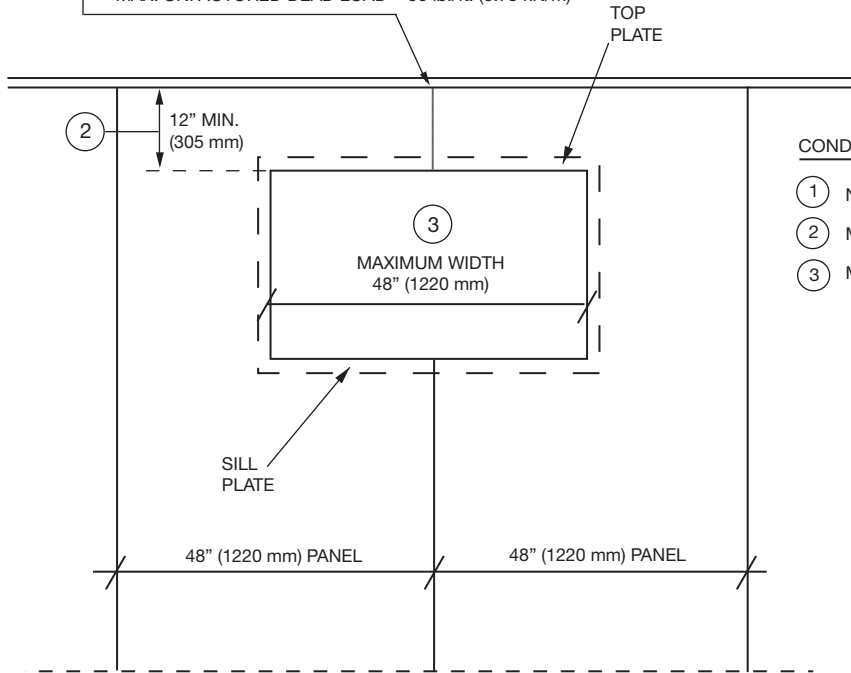

CONDITIONS

- ① NON-LOAD BEARING WALL
- ② MINIMUM LINTEL HEIGHT OF 12" (305 mm)
- ③ MAXIMUM OPENING WIDTH OF 48" (1220 mm)

FOR ROUGH OPENINGS A DEPTH OF 1-1/2" (38 mm) OF FOAM IS REMOVED FROM THE PERIMETER OF THE OPENING. THE ROUTED SPACE IS THEN FILLED WITH MATERIAL CONSISTENT WITH THE THICKNESS OF THE PANEL CORE.

THESE ARE SECURED IN PLACE WITH NAILS OR SCREWS @8" (203 mm) O/C MAX., TO CREATE THE ROUGH OPENING.

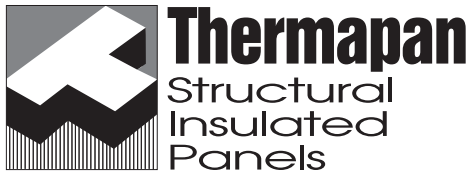
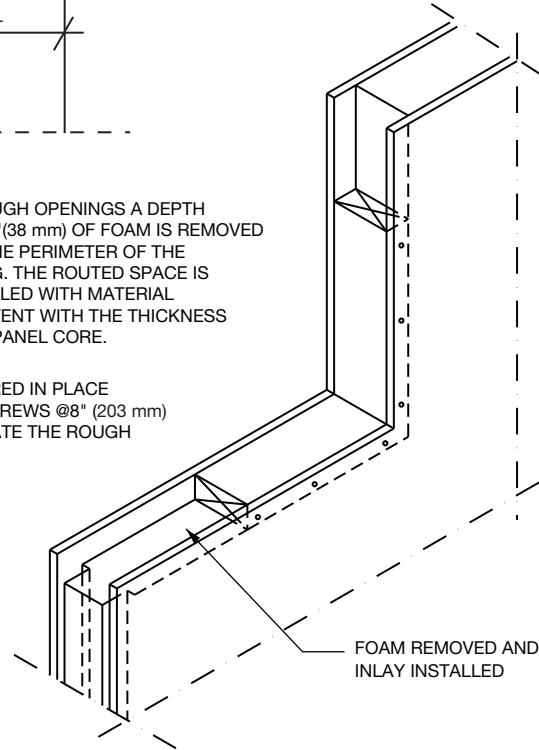

www.thermapan.com
1-877-443-WALL (9255)

TITLE		PROJECT	
WINDOW CUT-OUT (NON-LOAD BEARING WALL)			
REFERENCE	SCALE		
	N.T.S.		
DATE	REVISION	DWG. No.	
FEBRUARY 2012	2	W-7	

DETAIL 1

CONDITION 1:

- (1) MAX 9'-1" WALL HEIGHT
- (2) MAX 5,000 LBS. (22.3 kN) FACTORED REACTION
- (3) CONFIRM JACK POST REACTIONS
- (4) SINGLE JACK STUD

NOTE: REFER TO APPENDIX A OR DESIGN HANDBOOK FOR ALLOWABLE HEADER LOADS.

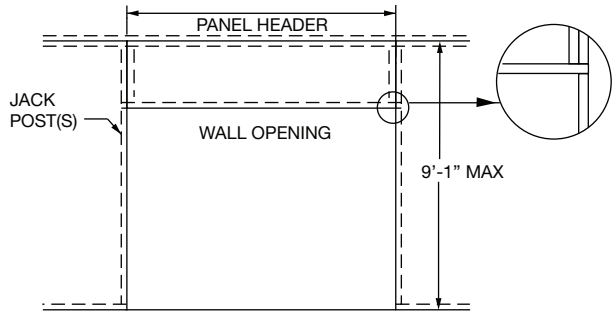

DETAIL 2

CONDITION 2:

- (1) $9'-1" \leq X \leq 12'$ (WALL HEIGHT)
- (2) MAX 5,000 LBS. (22.3 kN) FACTORED REACTION
- (3) CONFIRM JACK POST REACTIONS
- (4) SINGLE JACK AND KING STUD

NOTE: OSB TO BE ADDED TO BOTH SIDES OF STUDS WHEN ONLY 1-1/2" FOAM RECESS IS PROVIDED IN WALL PANEL. REFER TO APPENDIX A OR DESIGN HANDBOOK FOR ALLOWABLE HEADER LOADS.

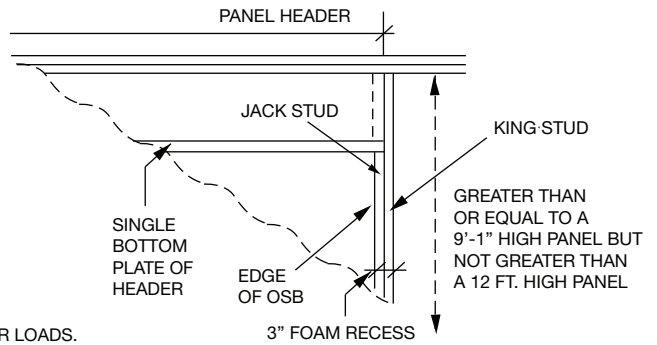

DETAIL 3

INSTALLING STUDS:

- 1. REMOVE OSB ONE SIDE
- 2. REMOVE FOAM
- 3. INSTALL STUDS
- 4. REPLACE OSB

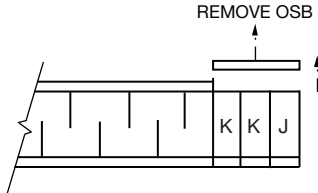

CONDITION 3:

- (1) $X \geq 12'$ (WALL HEIGHT)
- (2) MAX 5000 LBS. (22.3 kN) FACTORED REACTION
- (3) CONFIRM JACK POST REACTIONS
- (4) SINGLE JACK AND DOUBLE KING STUDS

NOTE: REFER TO APPENDIX A OR DESIGN HANDBOOK FOR ALLOWABLE HEADER LOADS.

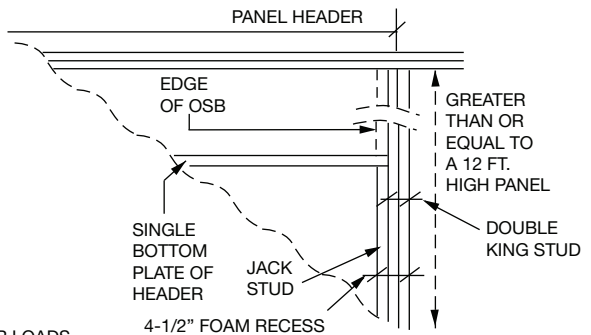

DETAIL 4

INSTALLING STUDS:

- 1. REMOVE OSB ONE SIDE
- 2. REMOVE FOAM
- 3. INSTALL STUDS
- 3. REPLACE OSB

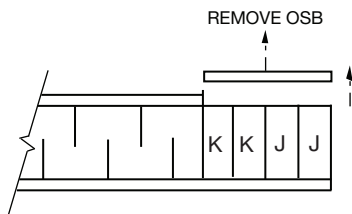

CONDITION 4:

- (1) $X \geq 12'$ (WALL HEIGHT)
- (2) MAX 10,000 LBS. (44.6 kN) FACTORED REACTION
- (3) CONFIRM JACK POST REACTIONS
- (4) DOUBLE JACK AND DOUBLE KING STUDS

NOTE: REFER TO APPENDIX A OR DESIGN HANDBOOK FOR ALLOWABLE HEADER LOADS.

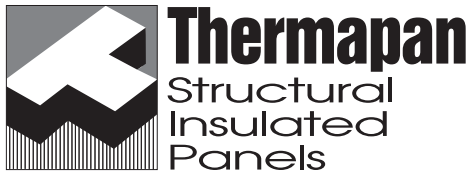
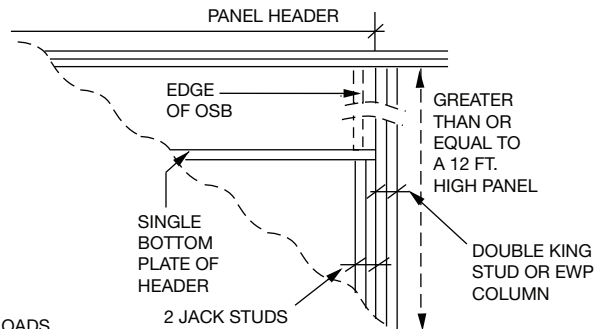

www.thermapan.com
1-877-443-WALL (9255)

TITLE		PROJECT	
PANEL LINTEL/HEADER DETAILS & BEARING CONDITIONS 1 - 4			
		N.T.S.	
DATE	REVISION	DWG. No.	
NOVEMBER 2023	1	W-8	

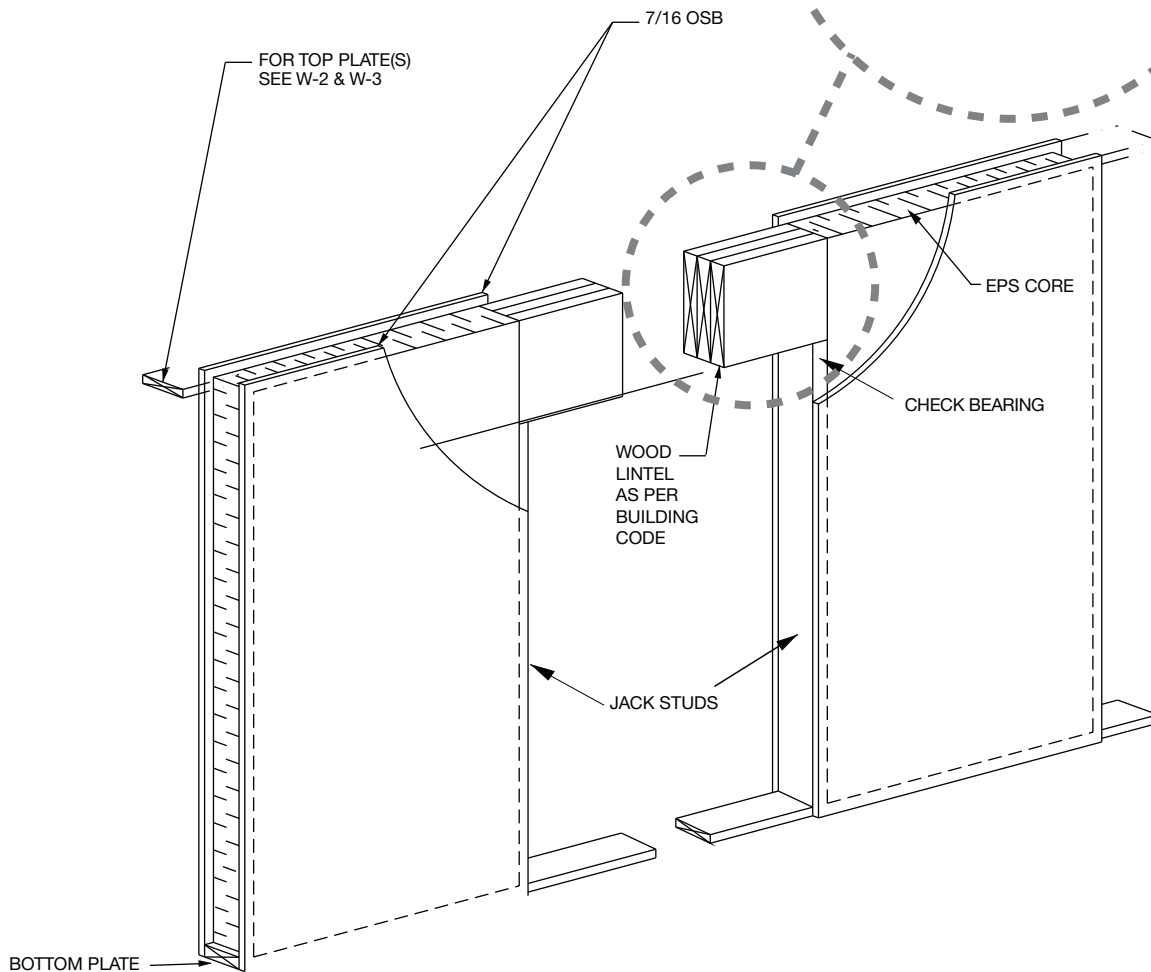
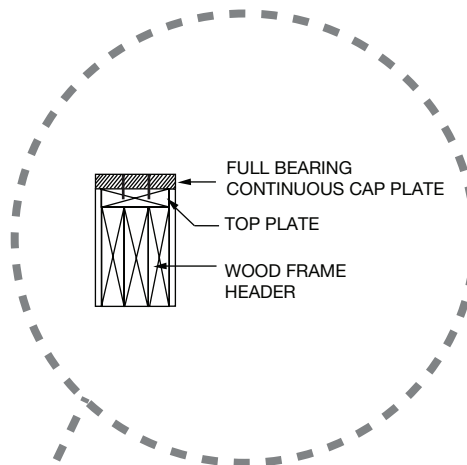
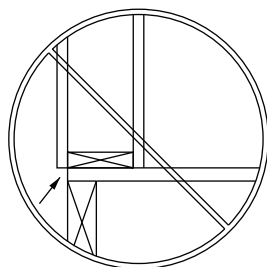

Thermapan
Structural
Insulated
Panels

www.thermapan.com
1-877-443-WALL (9255)

TITLE		PROJECT	
<p style="text-align: center;">LINTEL DETAIL (HEADER BY OTHERS)</p>			
		REFERENCE	SCALE
		N.T.S.	
DATE	REVISION	DWG. No.	
NOVEMBER 2021	5	W-9	

COLUMN (BUILT-UP STUDS, TIMBER, STEEL, ETC.)
INSTALL AS PER LOCAL BUILDING CODE.

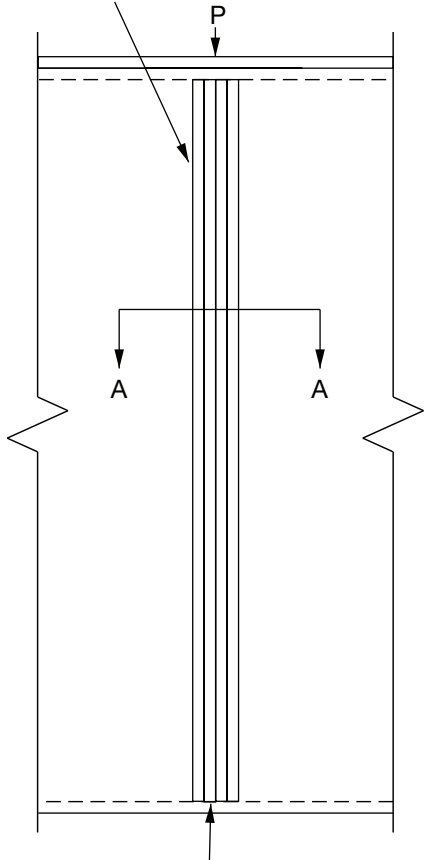

REMOVE BOTTOM PLATE SECTION AND INSTALL
COLUMN DIRECTLY ONTO FLOOR IF LOAD IS GREATER
THAN BEARING RESISTANCE OF WOOD PLATE.

SECTION A-A

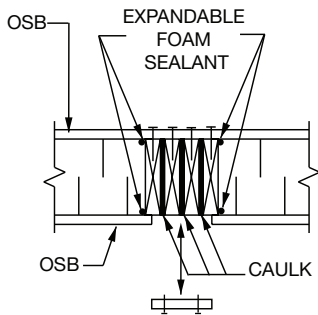

**TYPICAL STEEL POST
TO SIP CONNECTIONS**

FASTEN WOOD BLOCKING TO STEEL
COLUMN USING STEEL-TO-WOOD
SCREWS AND FASTEN SIP PANEL SKIN
TO BLOCKING USING
8d NAILS @ 6" O.C. TYP.

**WIDE FLANGE
STEEL POST**

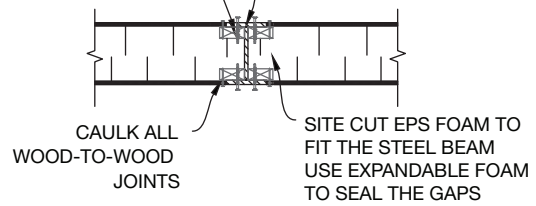

FASTEN STRIP OF
OSB/PLYWOOD
TO SIP SKIN USING 8d
NAILS @ 6" O.C. TYP.

**WIDE FLANGE
STEEL POST**

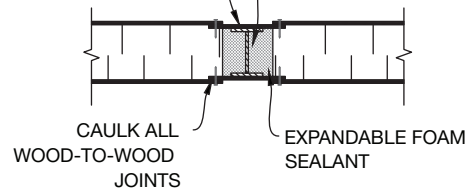

FASTEN STRIP OF
OSB/PLYWOOD
TO SIP SKIN USING 8d
NAILS @ 6" O.C. TYP.

**ROUND
STEEL POST**

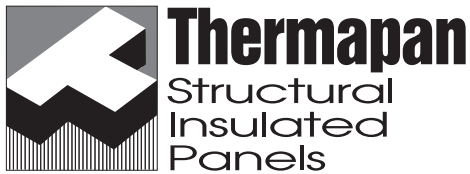
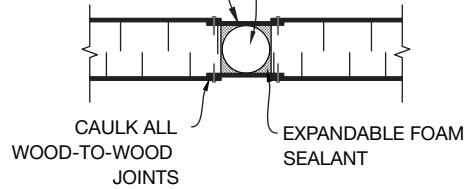

www.thermapan.com
1-877-443-WALL (9255)

TITLE		PROJECT	
POINT LOAD DETAIL			
REFERENCE	SCALE		DWG. No.
	N.T.S.		
DATE	REVISION	DWG. No.	
AUGUST 2025	5	W-10	

KNEE WALL SET
 ONTO FLOOR FOR
 ATTIC OR RAISED
 ROOF SPACE
 ENCLOSURE

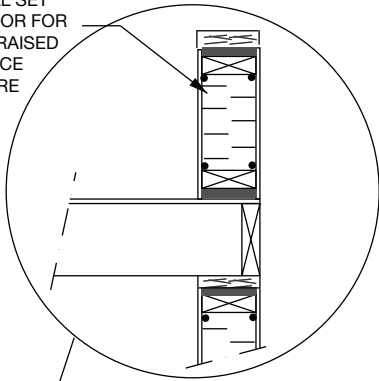

REFER TO WALL
 DETAILS W-2 OR W-3

REFER TO WALL
 DETAIL W-24

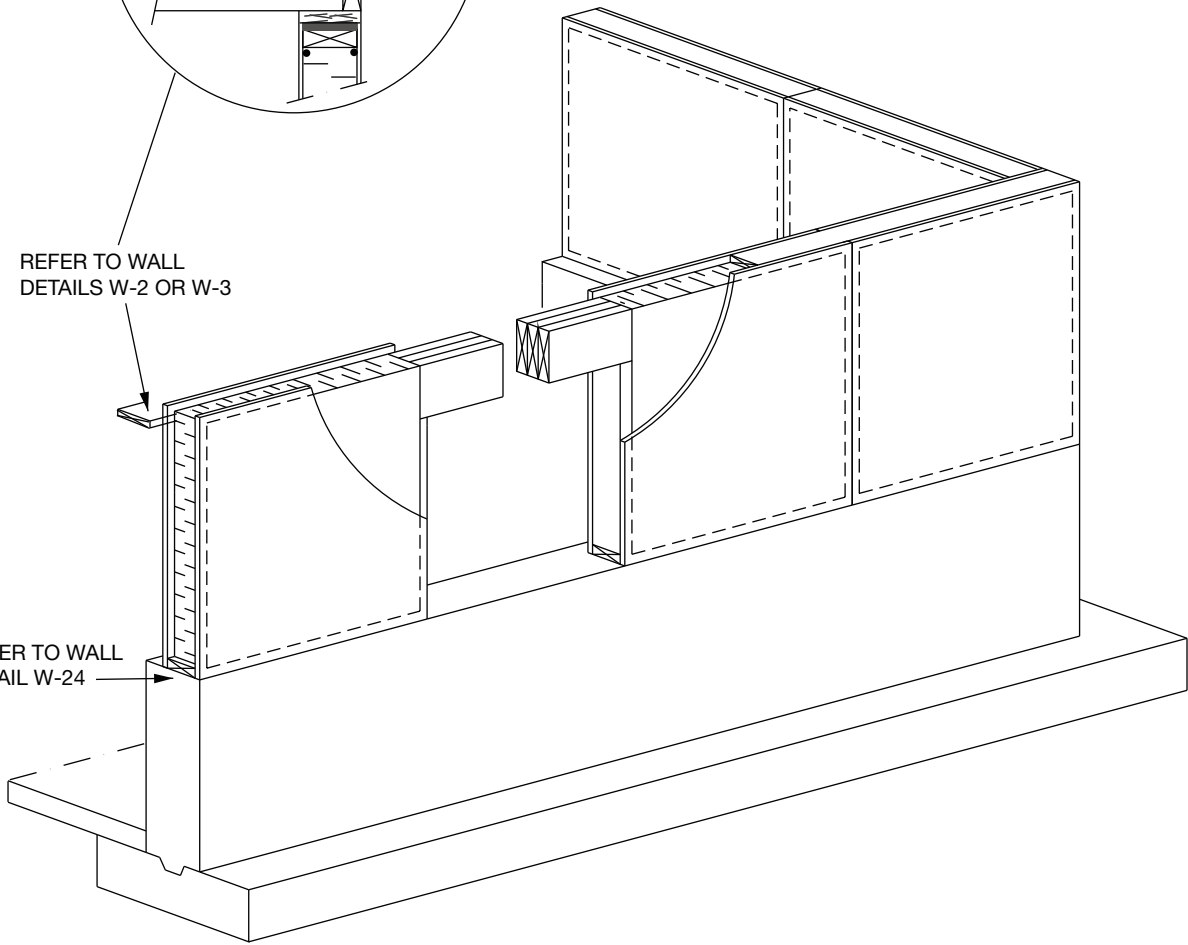

Thermapan
 Structural
 Insulated
 Panels

www.thermapan.com
 1-877-443-WALL (9255)

TITLE		PROJECT	
KNEE WALL DETAIL			
REFERENCE	SCALE		
	N.T.S.		
DATE	REVISION	DWG. No.	
MAY 2009	1	W-11	

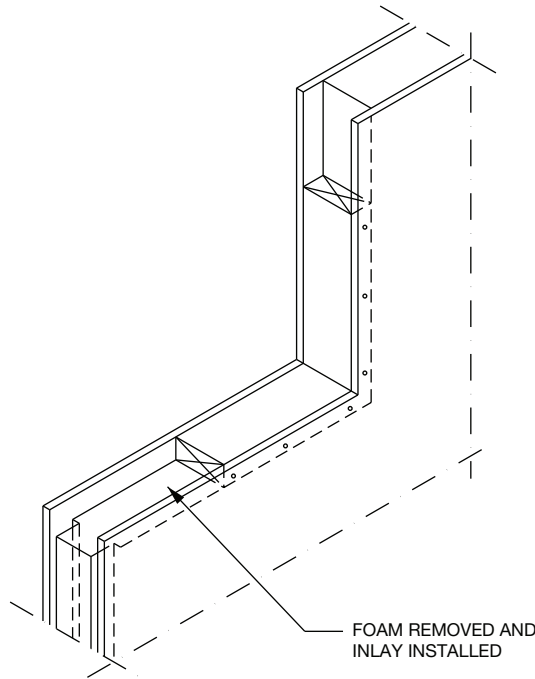
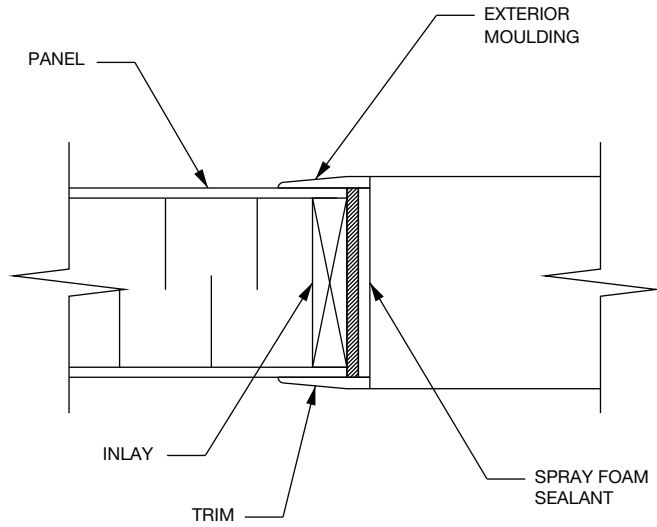
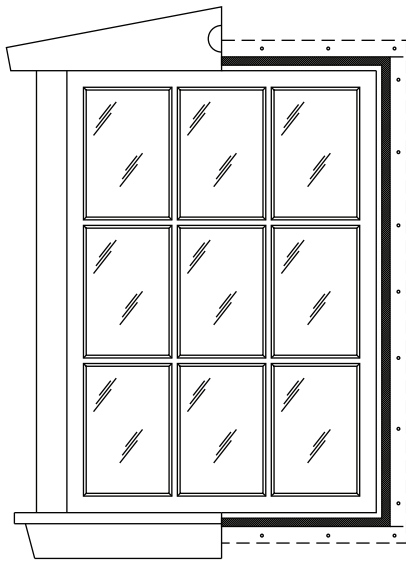

FOR ROUGH OPENINGS A DEPTH OF 1 1/2 " OF FOAM IS REMOVED FROM THE PERIMETER OF THE OPENING. THE ROUTED SPACE IS THEN FILLED WITH A MATERIAL CONSISTENT WITH THE THICKNESS OF THE PANEL CORE.

THESE ARE SECURED IN PLACE WITH NAILS OR SCREWS @8" O/C MAX., TO CREATE THE ROUGH OPENING.

THE WINDOW OR DOOR IS THEN INSTALLED CONVENTIONALLY.

NOTE: REFER TO LINTEL DETAILS W-7.



www.thermapan.com
1-877-443-WALL (9255)

TITLE		PROJECT	
DOOR & WINDOW ROUGH OPENINGS			
REFERENCE	SCALE	N.T.S.	
DATE	REVISION		
FEBRUARY 2012	3	DWG. No. W-12	

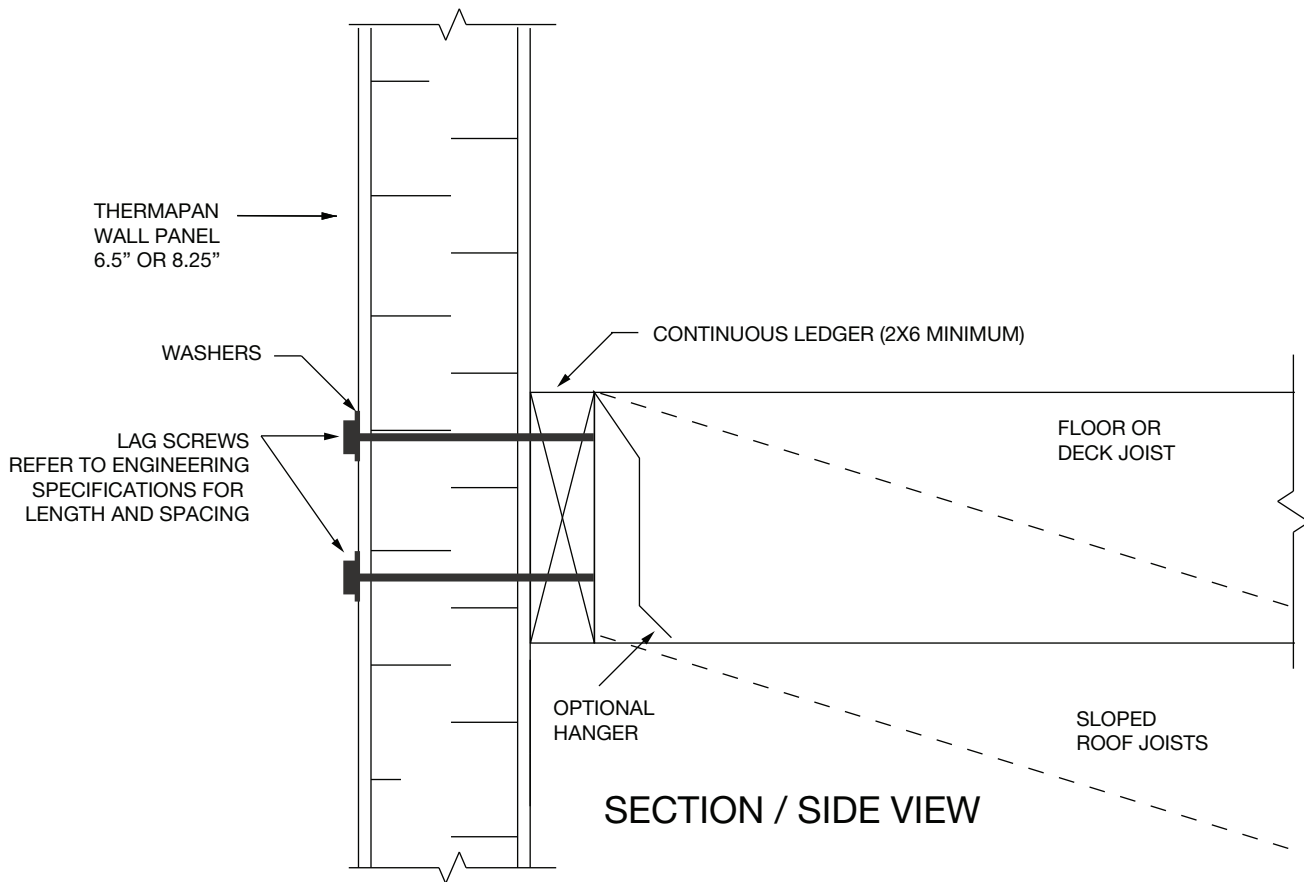

LEDGER CAN ALSO BE NAILED OR SCREWED (3.5" LONG) INTO LUMBER SPLINES (IF USED) AT 4' O/C

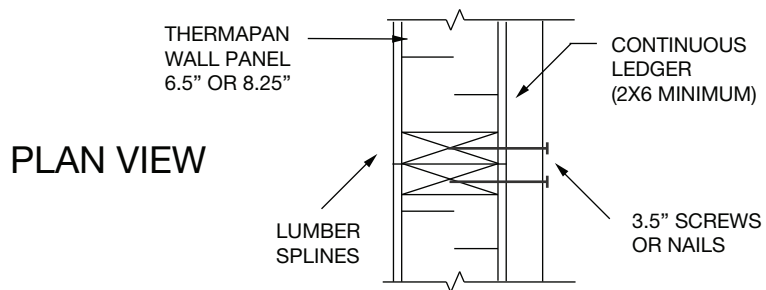

www.thermapan.com
1-877-443-WALL (9255)

TITLE		PROJECT	
WOOD LEDGER ATTACHED TO SIP WALL PANEL [®]			
REFERENCE	SCALE	NTS	
DATE	REVISION	DWG. No.	
APRIL 2020	3	W-13	

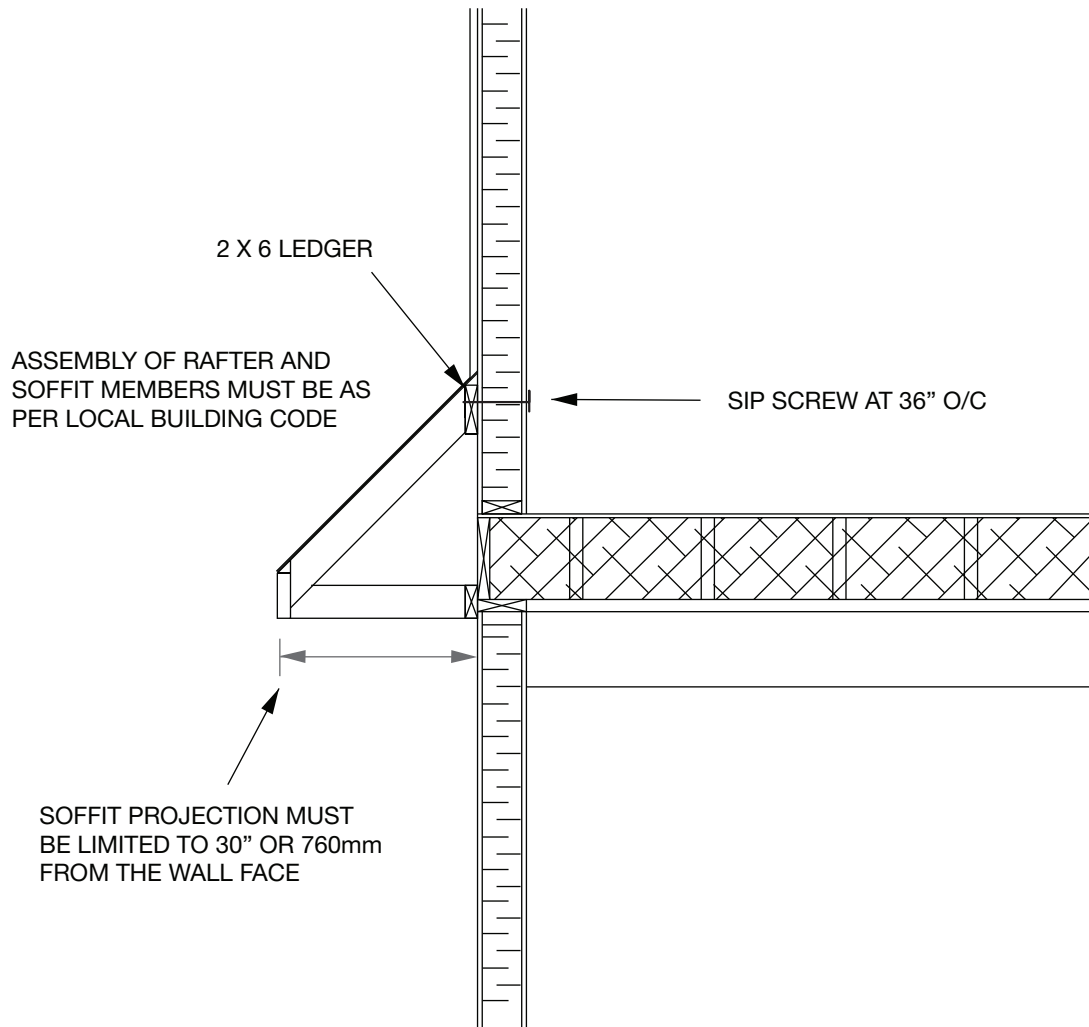

www.thermapan.com
1-877-443-WALL (9255)

TITLE		PROJECT	
KICKER TRUSS DETAIL			
REFERENCE	SCALE		
	N.T.S.		
DATE	REVISION	DWG. No.	
OCTOBER 2021	1	W-14	

ISOMETRIC

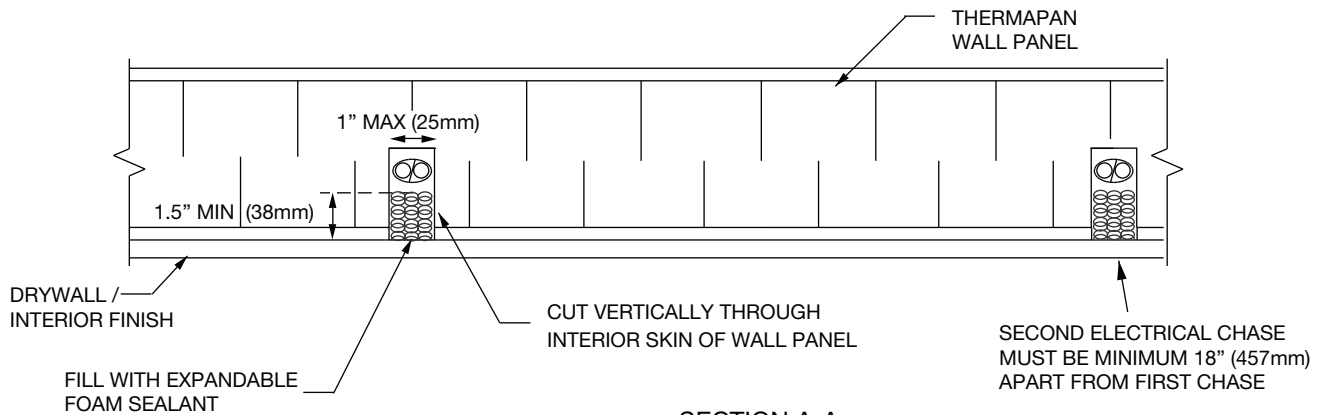
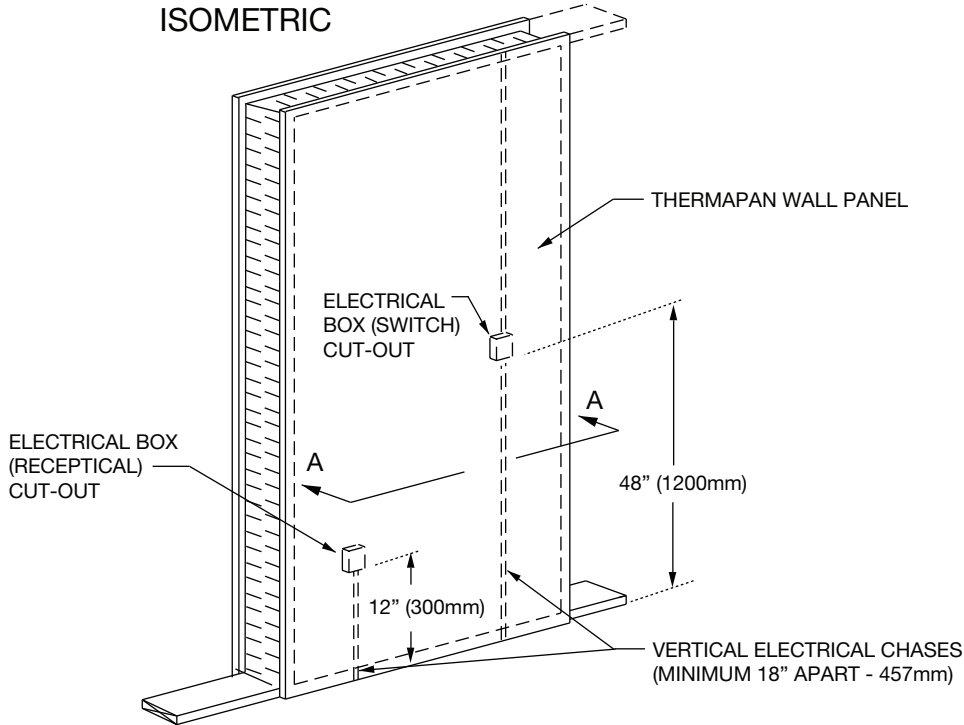

SECTION A-A

NOTES:

1. MAXIMUM OF TWO (2) VERTICAL CHASES PERMITTED FOR WALL PANELS 2'-6" (760mm) TO 4' (1220 mm) WIDE, MINIMUM 18"(457mm) APART.
2. MAXIMUM OF ONE (1) VERTICAL CHASE PERMITTED FOR WALL PANELS LESS THAN 2'-6" WIDE (760mm) .

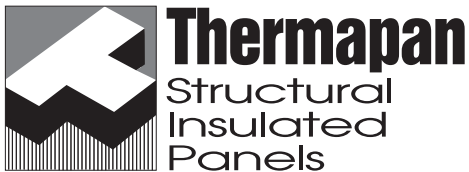

www.thermapan.com
1-877-443-WALL (9255)

TITLE		PROJECT	
VERTICAL ELECTRICAL CHASE [®]			
REFERENCE	SCALE		
DATE	REVISION	DWG. No.	
FEBRUARY 2018	2	W-15	

MASONRY VENEER

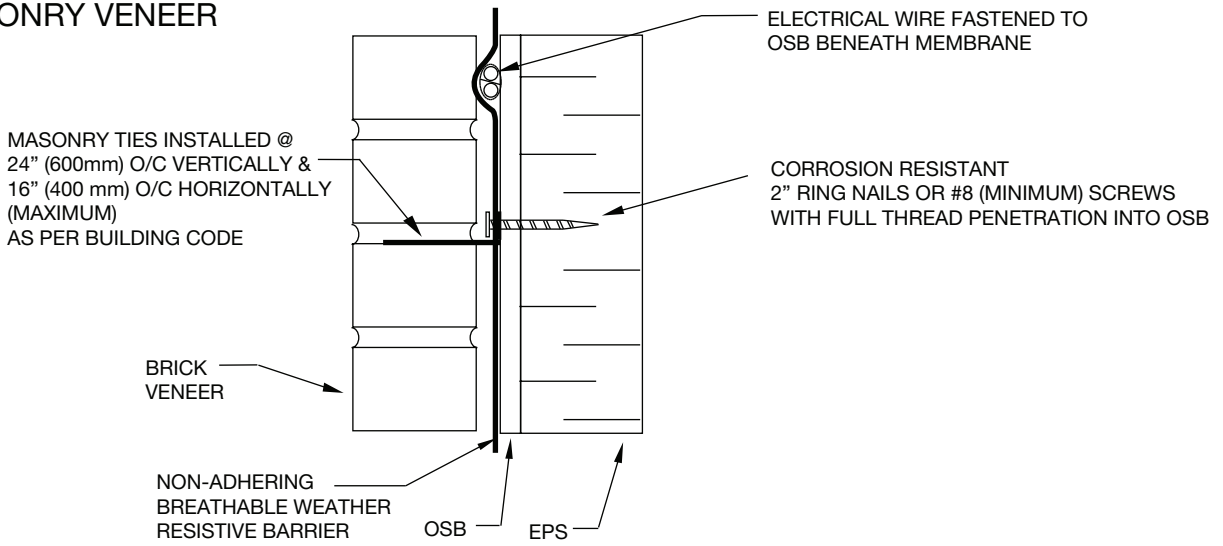

WOOD SIDING

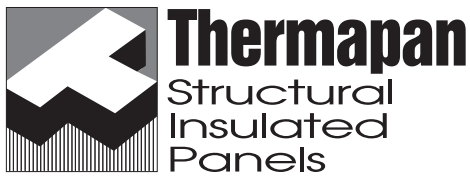
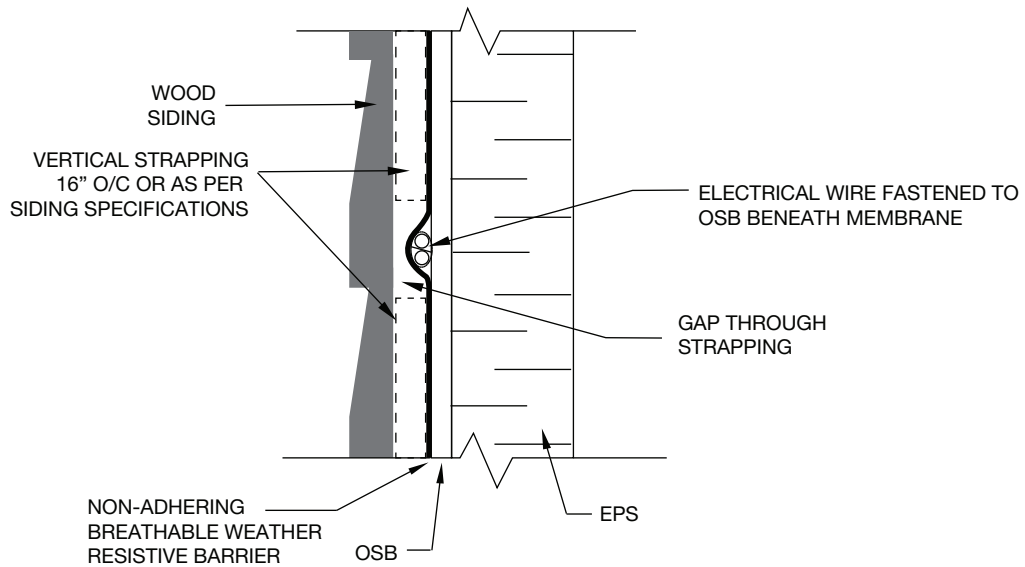

www.thermapan.com
1-877-443-WALL (9255)

TITLE		PROJECT	
ELECTRICAL WIRE FASTENED TO SIP EXTERIOR			
REFERENCE	SCALE		
	N.T.S.		
DATE	REVISION	DWG. No.	
MARCH 2026	1	W-16	

MASONRY VENEER

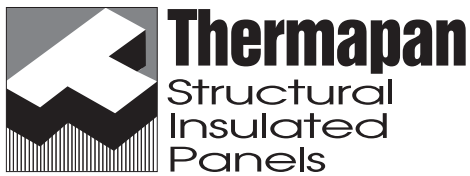
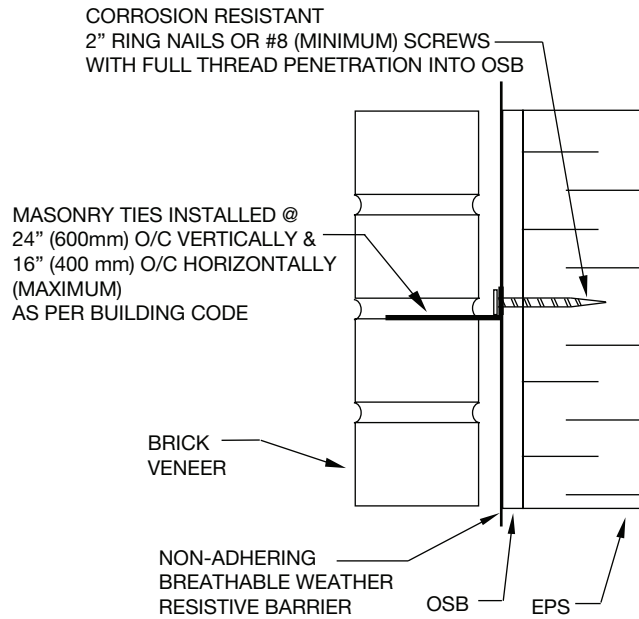
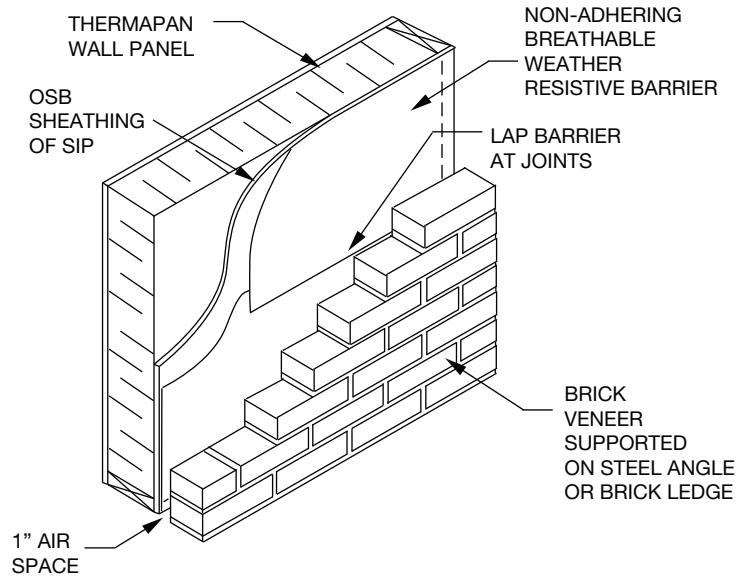

www.thermapan.com
1-877-443-WALL (9255)

TITLE		PROJECT	
EXTERIOR WALL CLADDING BRICK & CULTURED STONE			
REFERENCE	SCALE		
	N.T.S.		
DATE	REVISION	DWG. No.	
MARCH 2023		W-17	

STUCCO
(TRADITIONAL)

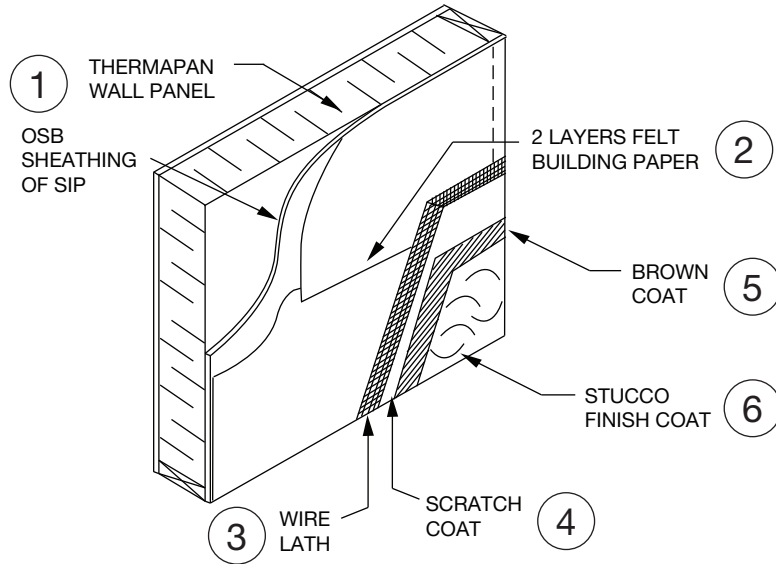

STUCCO
(EIFS)

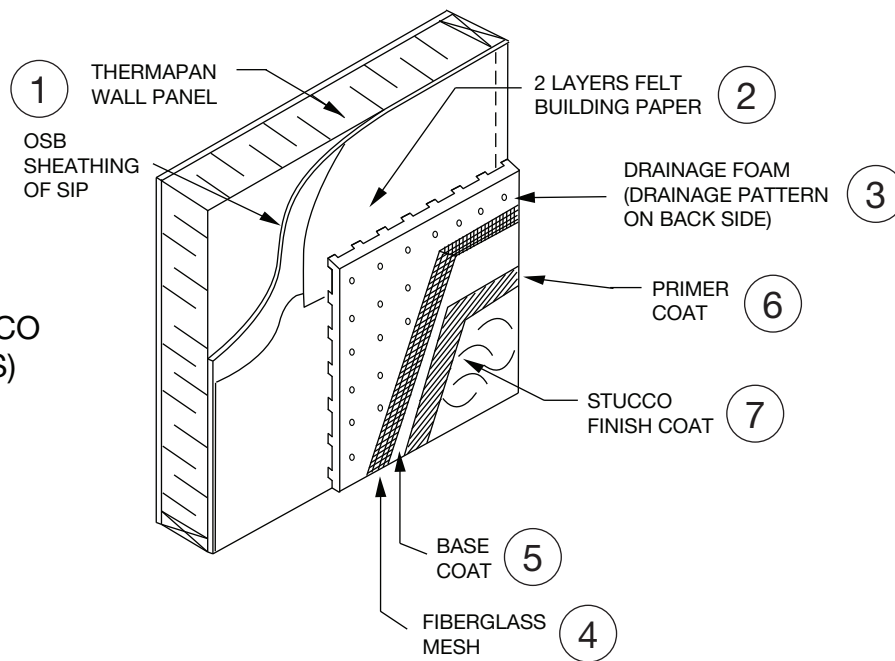

www.thermapan.com
1-877-443-WALL (9255)

TITLE

EXTERIOR WALL CLADDING
STUCCO (TRADITIONAL & EIFS)

PROJECT

REFERENCE

SCALE

N.T.S.

DATE

MARCH 2023

REVISION

DWG. No.

W-18

VINYL SIDING

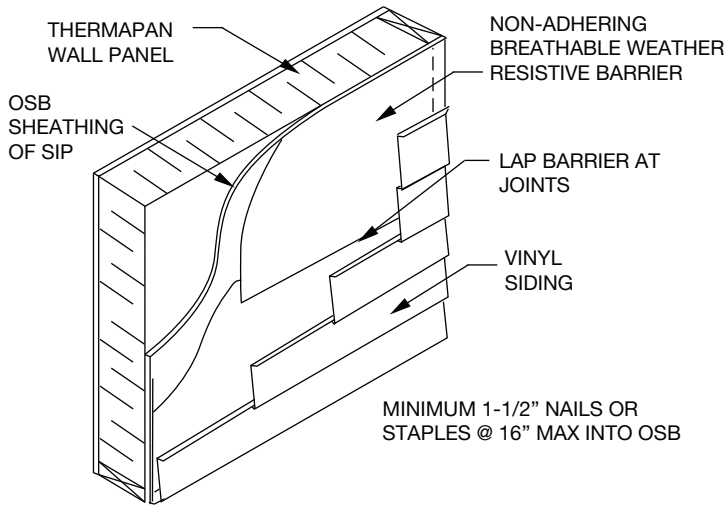

MINIMUM 1-1/2" NAILS OR STAPLES @ 16" MAX INTO OSB

FIBRE CEMENT SIDING

FOR FIBRE CEMENT LAP SIDING REFER TO MANUFACTURER'S RECOMMENDED FASTENING METHODS.

WOOD SIDING

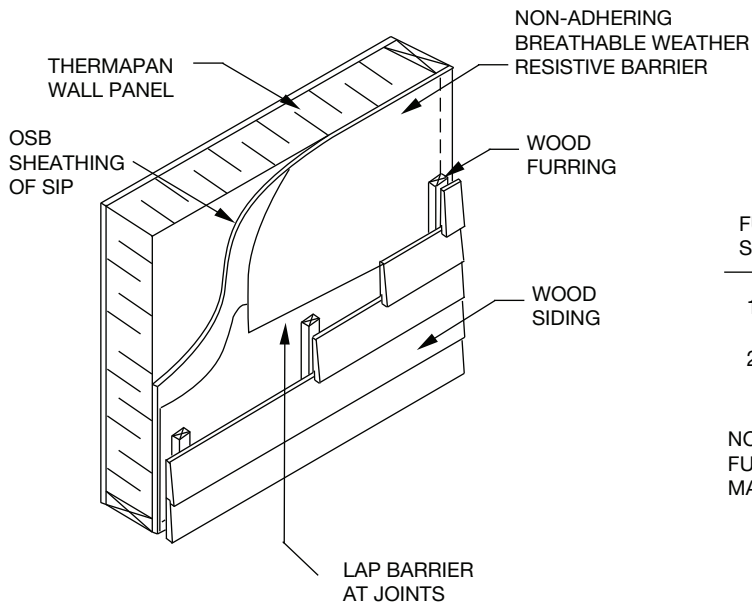

FURRING REQUIREMENTS (WOOD SIDING)

FURRING SPACING	FASTENER SPACING (MIN 1-1/2" SCREWS)	FASTENER SPACING (MIN 1-1/4" NAILS)
16" O/C	10" O/C	8" O/C
24" O/C	8" O/C	8" O/C

NOTE: ALL NAILS TO BE RING (ANNULARLY THREADED). FURRING TO BE AS RECOMMENDED BY SIDING MANUFACTURER.



www.thermapan.com
 1-877-443-WALL (9255)

TITLE

EXTERIOR WALL CLADDING:
 SIDING

PROJECT

REFERENCE

SCALE

N.T.S.

DATE

AUGUST 2017

REVISION

DWG. No.

3

W-19

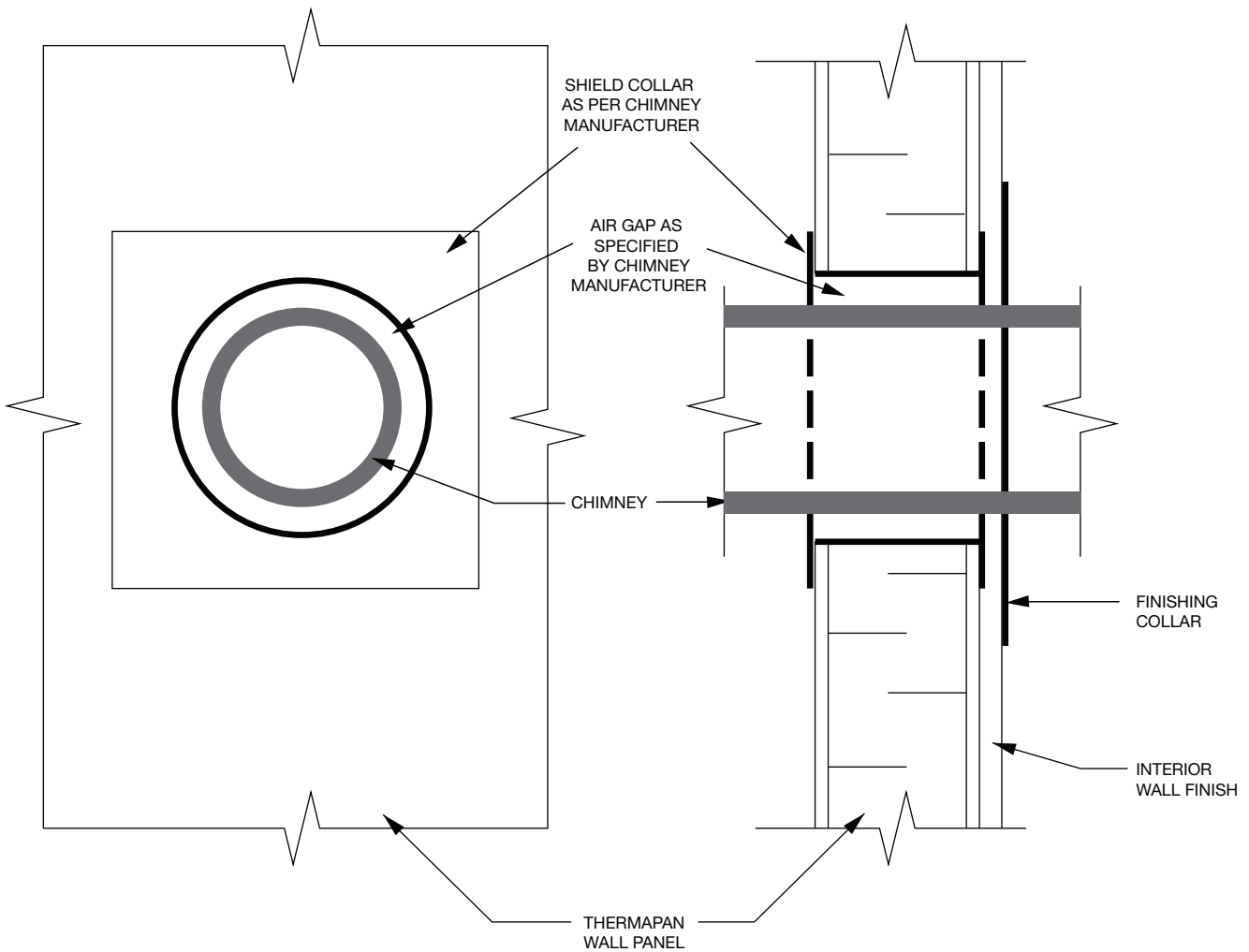

NOTE: ABOVE DETAILS ARE TYPICAL REQUIREMENTS TO INSTALL A PREFABRICATED METAL CHIMNEY IN A THERMAPAN STRUCTURAL INSULATED PANEL. THE CHIMNEY INSTALLATION MUST COMPLY WITH THE CHIMNEY MANUFACTURERS'S SPECIFICATION AND THE APPLICABLE BUILDING CODE.

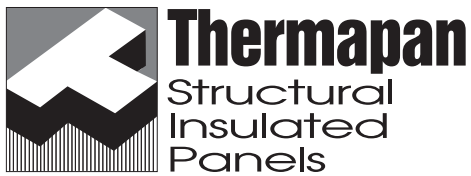

www.thermapan.com
1-877-443-WALL (9255)

TITLE		PROJECT	
PRE-FABRICATED METAL CHIMNEY INSTALLATION IN WALL			
REFERENCE	SCALE		
	N.T.S.		
DATE	REVISION	DWG. No.	
FEBRUARY 2019		W-21	

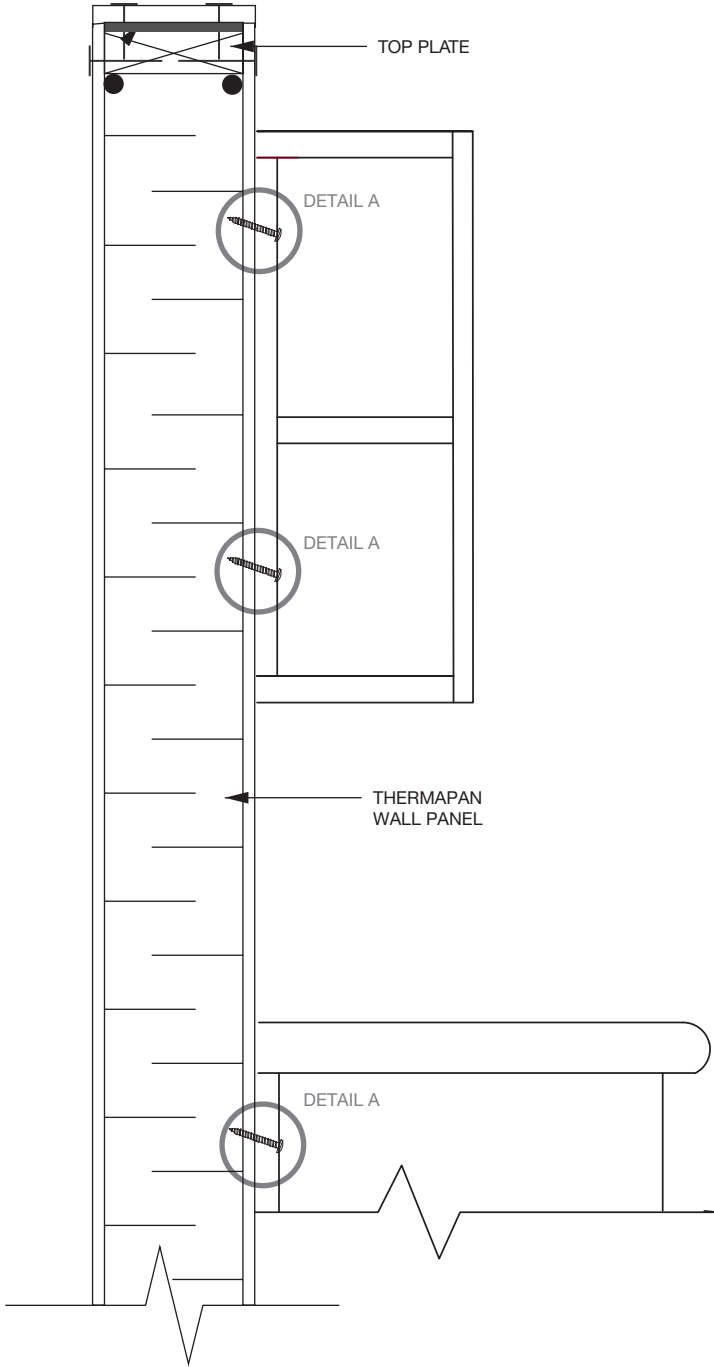

DETAIL A

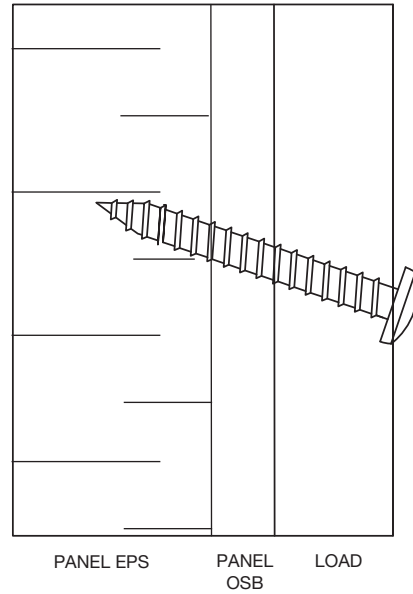

NOTE: NUMBER 10 TYPE A SHEET METAL SCREWS CAN RESIST A PULL OUT OF 106 POUNDS IN 7/16" OSB. CONTRACTOR TO CONFIRM LOAD TO BE SECURED AND NUMBER OF FASTENERS REQUIRED. FULL THICKNESS OF OSB TO RECEIVE SCREW THREAD ON ANGLE AS DETAILED

*THE GIVEN LOAD CAPACITY OF THE SCREW IS BASED ON THE AVERAGE ULTIMATE FAILURE LOAD DIVIDED BY A FACTOR OF SAFETY OF 3 AND TAKING INTO ACCOUNT A LONG TERM LOAD DURATION FACTOR OF 0.9. DESIGNERS MUST USE THE APPROPRIATE SAFETY FACTOR AND LOAD DURATION FACTOR FOR EACH LOADING CONDITION.

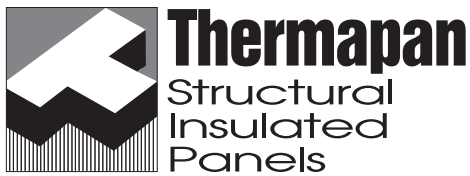

www.thermapan.com
1-877-443-WALL (9255)

TITLE		PROJECT	
SCREW FASTENER DETAIL FOR SECURING SHELVING TO THERMAPAN PANEL			
REFERENCE	SCALE		
	N.T.S.		
DATE	REVISION	DWG. No.	
MARCH 2022	1	W-22	

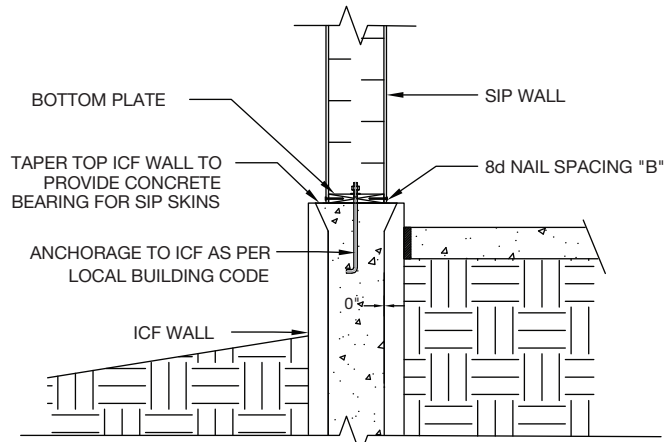

**SIP WALL TO ICF CONNECTION
(TAPERED TOP OF ICF WALL)**

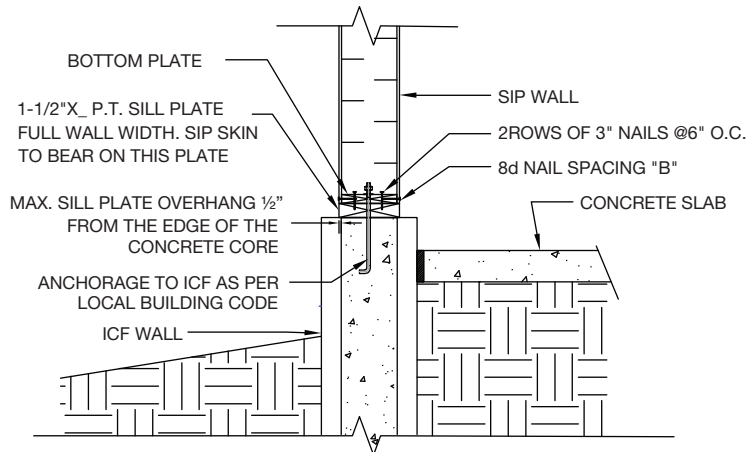

**SIP WALL TO ICF CONNECTION
(SQUARE TOP OF ICF WALL)**

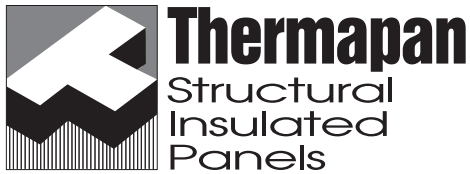

www.thermapan.com
1-877-443-WALL (9255)

TITLE		PROJECT	
REFERENCE		WALL SIP TO ICF CONNECTION DETAIL	
		SCALE	
DATE		REVISION	DWG. No.
MARCH 2024		1	W-23
		N.T.S.	

NOTE:

1. THE CONCRETE CONTRACTOR SHALL ENSURE THAT THE KNEE WALL IS DESIGNED TO RESIST LATERAL LOADS AT THE BASE OF THE SIP WALL.
2. THE CONTRACTOR SHALL ENSURE THAT ALL SIP SKINS (OSB) BEAR FULLY ON THE CONCRETE WALLS. OFFSETTING OF SIP SKINS IS NOT PERMITTED.

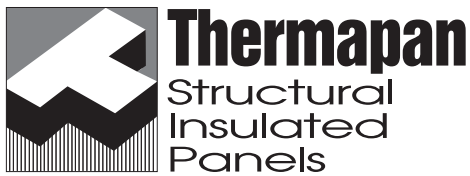
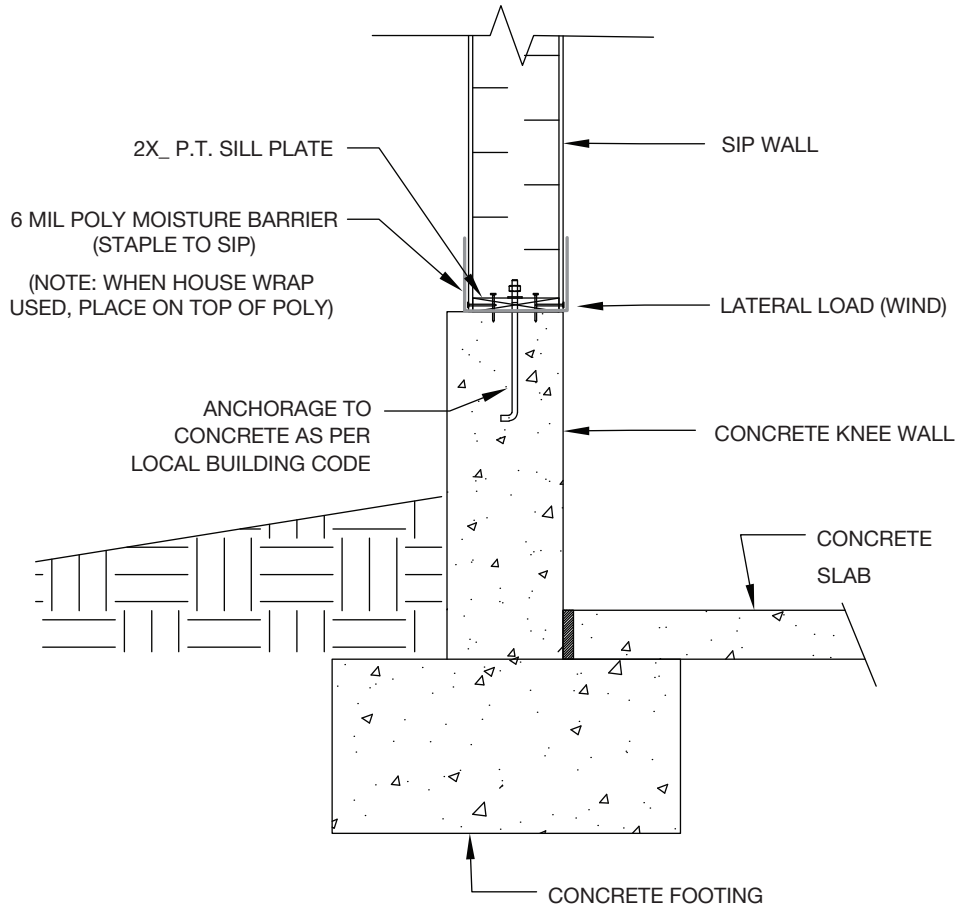

www.thermapan.com
1-877-443-WALL (9255)

TITLE		PROJECT	
SIP WALL TO CONCRETE KNEE WALL CONNECTION			
REFERENCE	SCALE		
	N.T.S.		
DATE	REVISION	DWG. No.	
DECEMBER 2025	1	W-24	

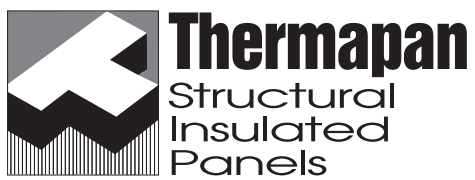
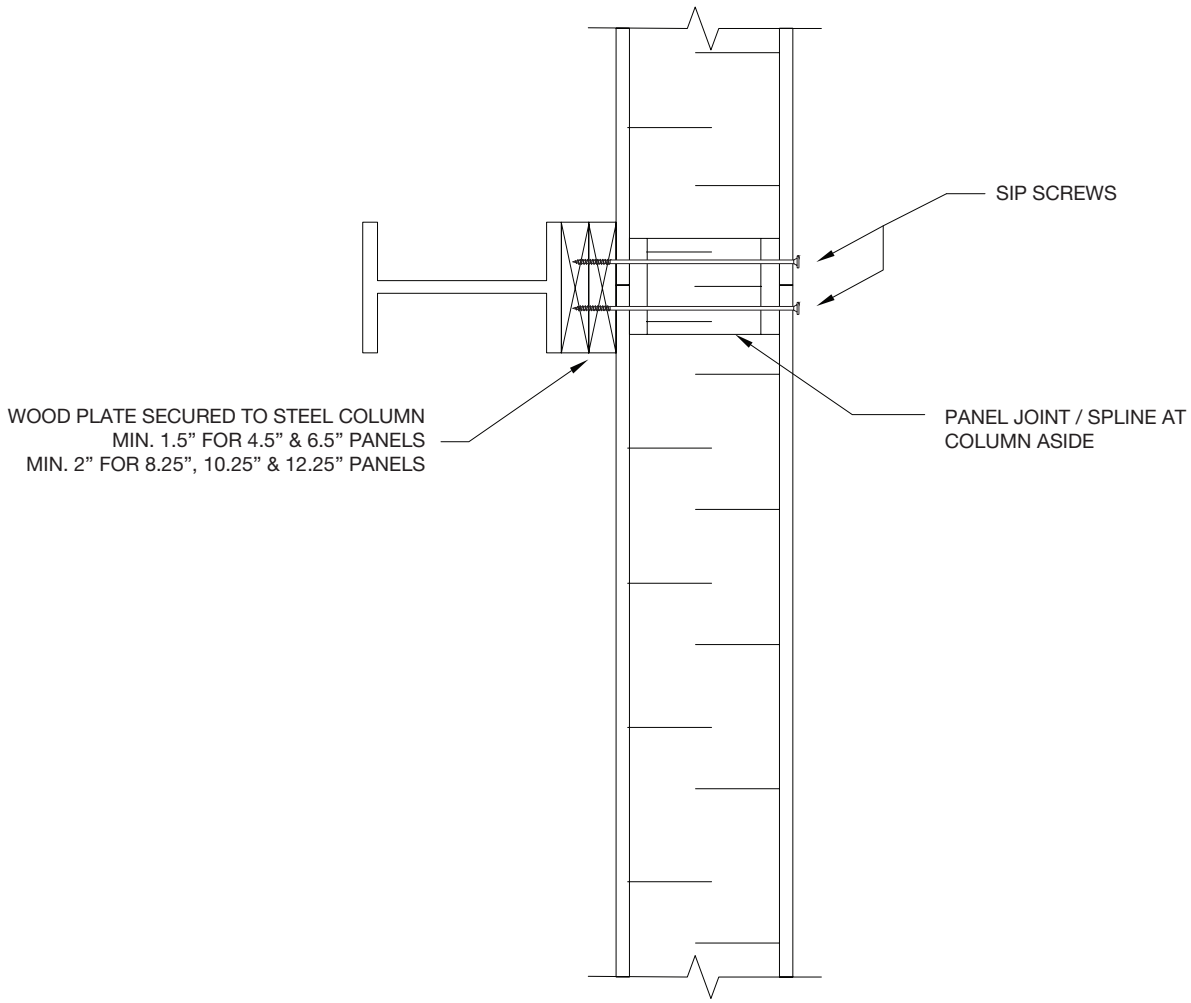

www.thermapan.com
1-877-443-WALL (9255)

TITLE		PROJECT	
REFERENCE		SCALE	
		N.T.S.	
DATE	REVISION	DWG. No.	
MARCH 2026		W-25	

TRUSSES INSTALLED AS PER LOCAL BUILDING CODE

5/8" TYPE C GYPSUM BD.
5/8" TYPE C GYPSUM BD.
SONOSECUR ACOUSTICAL PANEL
(one side only)
1/2" RESILIENT CHANNEL RC-1
6 1/2" STRUCTURAL FOAM
CORE PANEL

CONT. FIRE RATED
CAULKING TYP.

INSTALL AS PER LOCAL
BUILDING CODE OR JOIST
SUPPLIER SPEC.

5/8" TYPE C GYPSUM BD.
5/8" TYPE C GYPSUM BD.
SONOSECUR ACOUSTICAL PANEL
(one side only)
1/2" RESILIENT CHANNEL RC-1
6 1/2" STRUCTURAL FOAM
CORE PANEL

CONT. FIRE RATED CAULKING TYP.

INSTALL AS PER LOCAL
BUILDING CODE OR JOIST
SUPPLIER SPEC.

POURED CONCRETE OR
BLOCK FOUNDATION
WALL

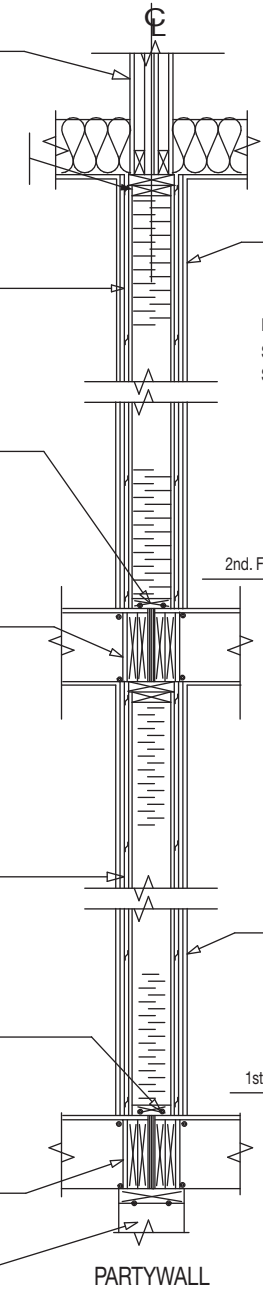

* UL / ULC LABELLED GYPSUM SHEATHING

STRUCTURAL CAPACITY FOR WALL
NOT TO EXCEED 32.4 kn/m
(2217 LBS. PER LINEAR FOOT)
FOR OTHER REQUIREMENTS,
INCLUDING STRUCTURAL LOAD,
REFER TO MANUFACTURER'S
INSTRUCTIONS.

INSTALL TOP PLATE AND CAP
SECURED TO STUDS WITH 95 mm
SPIRAL NAILS

50 mm RING NAILS
@ 250 mm O/C (TYP.)

5/8" TYPE C GYPSUM BD.
5/8" TYPE C GYPSUM BD.
1/2" RESILIENT CHANNEL

DOUBLE STUD SPLINE
SECURED TO PLATE WITH
83 mm SPIRAL NAILS

NOTE: TESTED IN CONFORMANCE WITH
CAN/ULC-S101-M, "FIRE ENDURANCE
TESTS OF BUILDING CONSTRUCTION AND
MATERIALS"



www.thermapan.com
1-877-443-WALL (9255)

TITLE

60 MIN. PARTYWALL
SINGLE WALL STC RATING 50

PROJECT

REFERENCE

SCALE

N.T.S.

DATE

JULY 2023

REVISION

9

DWG. No.

W-PW-1

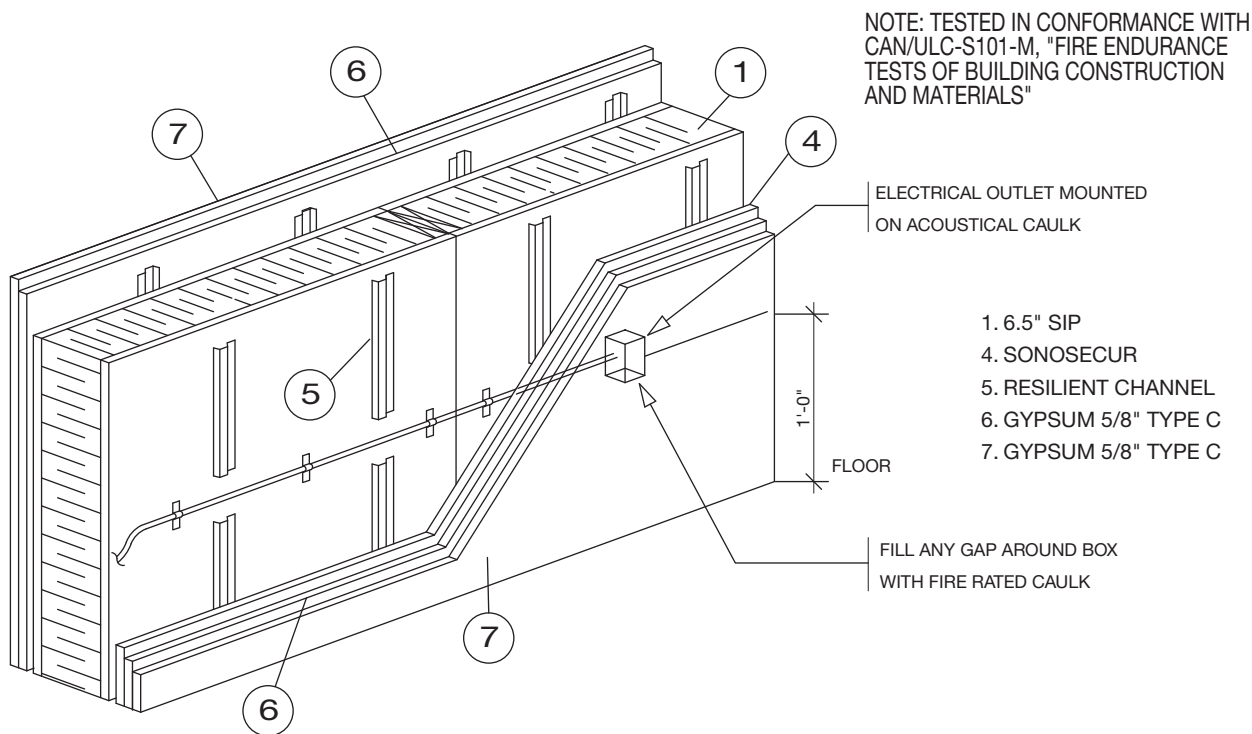

ASSEMBLY OF RESILIENT CHANNEL (5)

THE RESILIENT CHANNELS ARE ORIENTED VERTICALLY AT 16" (400 mm) OC AND SECURED WITH 1" (25 mm) TYPE W GYPSUM BOARD SCREWS AT 16" (400 mm) OC TO THE STRUCTURAL INSULATED PANEL (SIP)

ASSEMBLY OF SONOSECUR ACOUSTIC PANEL (4)

TACK THE SONOSECUR ACOUSTIC PANEL WITH 1" (25 mm) LONG TYPE W GYPSUM BOARD SCREWS TO HOLD IN PLACE. THE SONOSECUR ACOUSTIC PANEL IS ASSEMBLED ON ONE SIDE ONLY.

ASSEMBLY OF FIRST LAYER 5/8" TYPE C GYPSUM (6)

INSTALL THE FIRST GYPSUM LAYER (6) VERTICALLY ONTO RESILIENT CHANNELS WITH 1" (25 mm) TYPE W GYPSUM SCREWS SPACED 16" (400 mm) OC.

ASSEMBLY OF SECOND LAYER 5/8" TYPE C GYPSUM (7)

THE JOINTS OF THE SECOND LAYER SHOULD BE OFFSET AND STAGGERED FROM FIRST LAYER. THE SECOND LAYER SHOULD HAVE 1.75" (44 mm) SCREWS AT 12" (304 mm) OC . THE FIRST LAYER OF GYPSUM DOES NOT HAVE TO BE TAPED. ONLY THE SECOND LAYER HAS TO BE FINISHED. JOINTS SHOULD BE COVERED WITH COMPOUND, COVERED WITH JOINT TAPE AND COVERED WITH AN ADDITIONAL TWO COATS OF JOINT COMPOUND. SCREW HEADS COVERED WITH JOINT COMPOUND.

UL GYPSUM BOARD FIRECODE "C"



www.thermapan.com
1-877-443-WALL (9255)

TITLE		PROJECT	
PARTYWALL ELECTRICAL DETAIL (60 MINUTE WALL RATED ASSEMBLY (SINGLE WALL) STC RATING 50)			
REFERENCE	SCALE		
8015	N.T.S.		
DATE	REVISION	DWG. No.	
JULY 2023	9	W-PW-2	

TRUSSES INSTALLED AS PER BUILDING CODE

5/8" TYPE C GYPSUM BD.
5/8" TYPE C GYPSUM BD.
SONOSECUR ACOUSTICAL PANEL
(one side only)
1/2" RESILIENT CHANNEL RC-1
4 1/2" STRUCTURAL FOAM
CORE PANEL

1" AIR SPACE

CONTINUOUS FIRE RATED CAULKING

INSTALL AS PER LOCAL BUILDING CODE OR JOIST SUPPLIER SPEC.

5/8" TYPE C GYPSUM BD.
5/8" TYPE C GYPSUM BD.
SONOSECUR ACOUSTICAL PANEL
(one side only)
1/2" RESILIENT CHANNEL RC-1
4 1/2" STRUCTURAL FOAM
CORE PANEL

1" AIR SPACE

CONTINUOUS FIRE RATED CAULKING

INSTALL AS PER LOCAL BUILDING CODE OR JOIST SUPPLIER SPEC.

POURED CONCRETE OR BLOCK WALL FOUNDATION

STRUCTURAL CAPACITY FOR WALL NOT TO EXCEED 32.4 kn/m (2217 LBS. PER LINEAR FOOT) FOR OTHER REQUIREMENTS, INCLUDING STRUCTURAL LOAD, REFER TO MANUFACTURER'S INSTRUCTIONS.

INSTALL TOP PLATE AND CAP SECURED TO STUDS WITH 95 mm SPIRAL NAILS

50 mm RING NAILS @ 250 mm O/C (TYP)

5/8" TYPE C GYPSUM BD.
5/8" TYPE C GYPSUM BD.
1/2" RESILIENT CHANNEL

DOUBLE STUD SPLINE SECURED TO PLATE WITH 83 mm SPIRAL NAILS

ULC LABELLED CANADIAN GYPSUM COMPANY "SHEETROCK FIRECODE C" OR "SHEETROCK SW FIRECODE C"

NOTE: TESTED IN CONFORMANCE WITH CAN/ULC-S101-M, "FIRE ENDURANCE TESTS OF BUILDING CONSTRUCTION AND MATERIALS"



www.thermapan.com
1-877-443-WALL (9255)

TITLE		PROJECT	
60 MIN. PARTYWALL DOUBLE WALL STC RATING 50			
REFERENCE	SCALE		
7016	N.T.S.		
DATE	REVISION	DWG. No.	
JULY 2023	6	W-PW-3	

NOTE: TESTED IN CONFORMANCE WITH CAN/ULC-S101-M, "FIRE ENDURANCE TESTS OF BUILDING CONSTRUCTION AND MATERIALS"

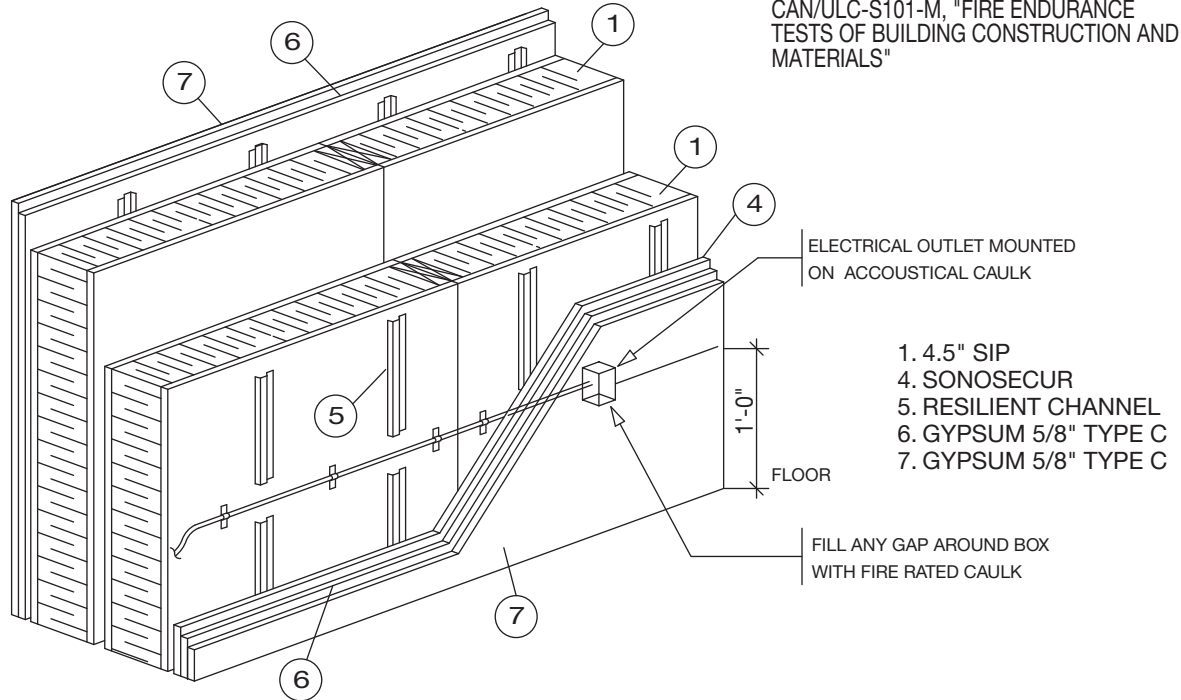

ASSEMBLY OF RESILIENT CHANNEL (5)

THE RESILIENT CHANNELS ARE ORIENTED VERTICALLY AT 16" (400 mm) OC AND SECURED WITH 1" (25 mm) TYPE W GYPSUM BOARD SCREWS AT 16" (400 mm) OC TO THE STRUCTURAL INSULATED PANEL (SIP).

ASSEMBLY OF SONOSECUR ACOUSTIC PANEL (4)

TACK THE SONOSECUR ACOUSTIC PANEL WITH 1" (25 mm) LONG TYPE W GYPSUM BOARD SCREWS TO HOLD IN PLACE. THE SONOSECUR ACOUSTIC PANEL IS ASSEMBLED ON ONE SIDE ONLY.

ASSEMBLY OF FIRST LAYER 5/8" TYPE C GYPSUM (6)

INSTALL THE FIRST GYPSUM LAYER (6) VERTICALLY ONTO RESILIENT CHANNELS WITH 1" (25 mm) TYPE W GYPSUM SCREWS SPACED 16" (400 mm) OC.

ASSEMBLY OF SECOND LAYER 5/8" TYPE C GYPSUM (7)

THE JOINTS OF THE SECOND LAYER SHOULD BE OFFSET AND STAGGERED FROM FIRST LAYER. THE SECOND LAYER SHOULD HAVE 1.75" (44 mm) SCREWS AT 12" (304 mm) OC . THE FIRST LAYER OF GYPSUM DOES NOT HAVE TO BE TAPED. ONLY THE SECOND LAYER HAS TO BE FINISHED. JOINTS SHOULD BE COVERED WITH COMPOUND, COVERED WITH JOINT TAPE AND COVERED WITH AN ADDITIONAL TWO COATS OF JOINT COMPOUND. SCREW HEADS COVERED WITH JOINT COMPOUND.

UL GYPSUM BOARD FIRECODE "C"



www.thermapan.com
1-877-443-WALL (9255)

TITLE		PROJECT	
PARTYWALL ELECTRICAL DETAIL (60 MIN. WALL RATED ASSEMBLY (DOUBLE WALL) STC RATING 50)			
REFERENCE	SCALE		
8015	N.T.S.		
DATE	REVISION	DWG. No.	
JULY 2023	7	W-PW-4	

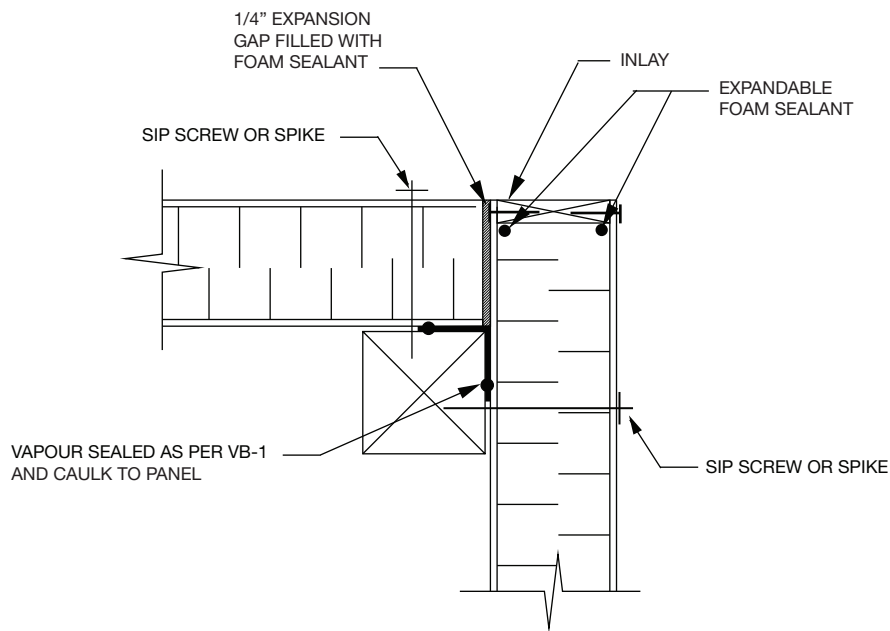
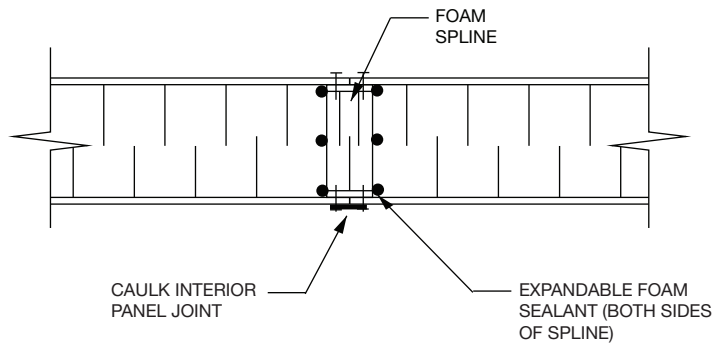

NOTE: REFER TO W-1 FOR SPLINE CONNECTION DETAILS. REFER TO AIR BARRIER (AB-1 & AB-2) DETAILS FOR SEALING SIP CONNECTIONS.

THE PANELS ARE FASTENED TO THE POST AT THE CORNERS AS SHOWN LEAVING A GAP TO BE SEALED WITH EXPANDING SPRAY FOAM.

DIMENSIONAL LUMBER INLAYS COMPLETE THE NAILING SURFACE AT THE CORNER.

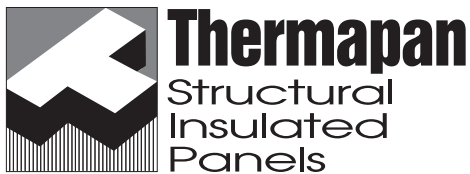

www.thermapan.com
1-877-443-WALL (9255)

TITLE		PROJECT	
VERTICAL PANEL CONNECTIONS SPLINE & CORNER (TIMBERFRAME)			
REFERENCE	SCALE		
	N.T.S.		
DATE	REVISION	DWG. No.	
APRIL 2014	6	W-TF-1	

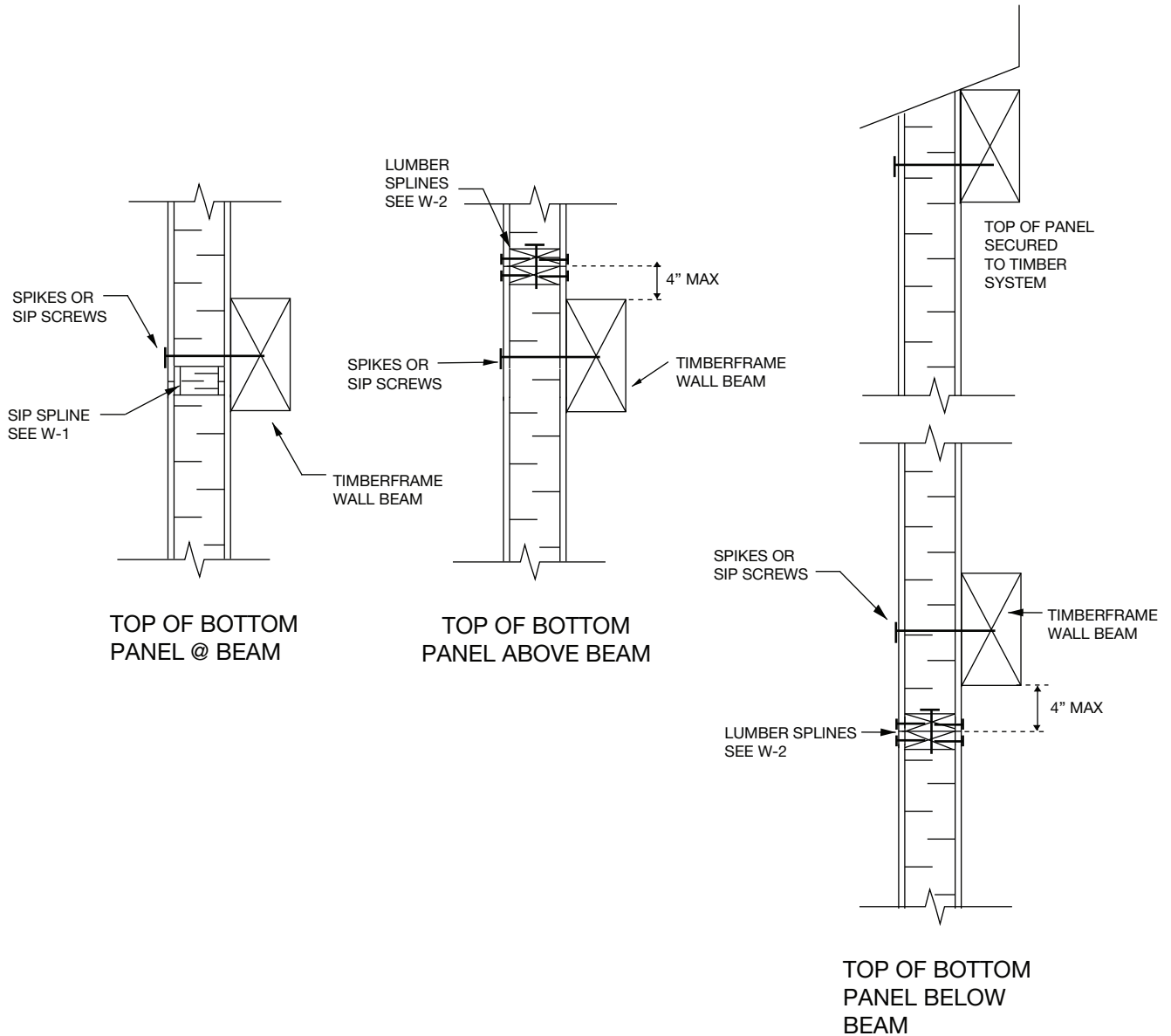

NOTE: REFER TO AIR BARRIER (AB-1 & AB-2) DETAILS FOR SEALING SIP CONNECTIONS.

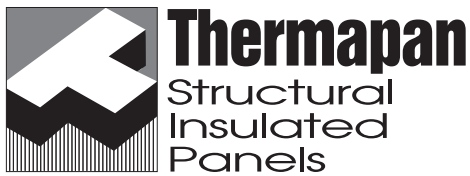

www.thermapan.com
1-877-443-WALL (9255)

TITLE		PROJECT	
HORIZONTAL CONNECTIONS AT BEAMS (TIMBERFRAME)			
REFERENCE	SCALE		
	N.T.S.		
DATE	REVISION	DWG. No.	
APRIL 2014	3	W-TF-2	

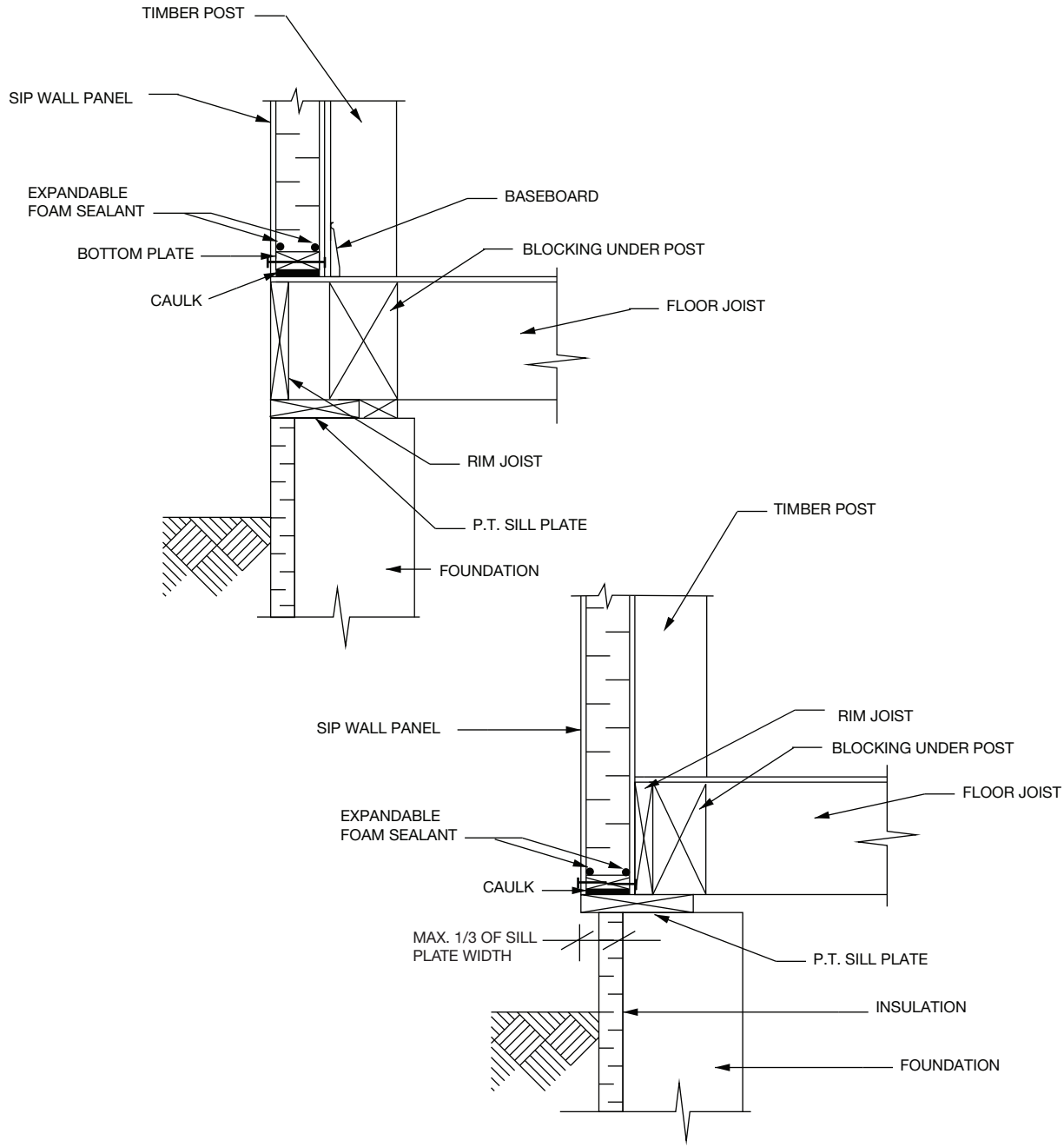

NOTE: REFER TO AIR BARRIER (AB-2) DETAIL FOR SEALING SIP CONNECTIONS.

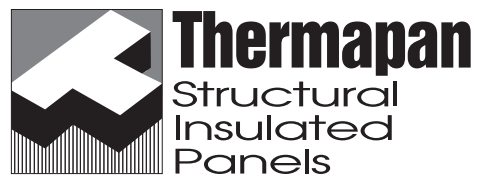

www.thermapan.com
1-877-443-WALL (9255)

TITLE		PROJECT	
FOUNDATION DETAILS DECK OPTIONS (TIMBERFRAME)			
REFERENCE	SCALE	N.T.S.	
DATE	REVISION	DWG. No.	
APRIL 2014	5	W-TF-3	