

The better way to build™



## Installation Manual FLOOR SIPs



**Thermapan**  
Structural  
Insulated  
Panels

## **FLOOR SIPs Installation Manual**

### **Table of Contents**

#### **Topics**

General Requirements . . . . .	3
Materials . . . . .	3
Protection from Dampness . . . . .	3
Interior Finish . . . . .	3
Electrical Wiring . . . . .	4
Plumbing . . . . .	4
Materials Estimation . . . . .	5

#### **Details**

Air Barrier Details for Air Barrier Sealants . . . . .	AB-1
Air Barrier Details for Sealing SIP Connections . . . . .	AB-2
Vapour Barrier Details for Vapour Sealing SIP Connections . . .	VB-1
Drawing FL-1: Floor Panel Details . . . . .	FL-1
Drawing FL-2: Floor Panel Connections (to Foundation or Existing Walls) . . . . .	FL-2
Drawing FL-3: Floor Panel Connections (to SIP Exterior and SIP Foundation Walls) . . . . .	FL-3
Drawing FL-4: Floor SIP to Steel Beam Connection . . . . .	FL-4

## **FLOOR SIPs**

### **Installation Manual**

#### **1. General Requirements**

##### **1.1 Scope**

The basic design and construction requirements for the Thermapan Structural Insulated Panel (SIP) floor systems are set forth in this specification. Criteria for materials, environmental control, design loads, and structural design are included. Where requirements are based on internationally recognized standards and specifications, these standards and specifications are referenced without elaboration.

**Installers shall reference engineering design package for fastening arrangements.**

#### **2. Materials**

##### **2.1 Floor SIP (See Detail FL-1)**

The Thermapan SIP is composed of an expanded polystyrene (EPS) foam core laminated between two layers of oriented strand board (OSB) with a structural adhesive.

**2.2** Framing Lumber shall be DOC PS 20 or NLGA No.2 or better.

**2.3** Wire nails, ring nails, spikes and staples shall conform to CSA B111 or ANSI B11.1.

**2.4** Wood screws shall conform to ANSI/ASME B18.6.1.

**2.5** SIP screws shall conform to ICC-AC233.

**2.6** Caulking Compounds shall conform to CAN/CGSB 19.13 or ASTM C 920.

**2.7** Polyethylene Sheeting shall conform to CAN/CGSB-37.2, CAN/CGSB-37.16, or ASTM D 4397.

**2.8** Low expansion foam seal shall conform to AAMA 812-04.

**2.9** Structural adhesive shall conform to CAN/CGSB 71GP26, APA AFG-01 or ASTM D3498.

#### **3. Decay and Termite Protection**

**3.1** The minimum vertical clearance between structural wood elements and the finished ground level is not to be less than 150 mm (6”).

**3.2** In localities where termites are known to occur, clearance between the exposed exterior osb skin of the floor SIP and the finished ground level directly below shall be not less than 450 mm (18”).

#### **4. Interior Finish**

- 4.1** A plywood underlay may be required for hardwood and ceramic tile finishes.

#### **5. Electrical Wiring**

- 5.1** It is recommended to fasten wiring to the exterior OSB layer and drill access through to interior layer.
- 5.2** Exposed wire shall conform to local building code.

#### **6. Plumbing**

- 6.1** Vertical plumbing penetrations 6" in diameter or less can be cut out of the floor SIP.

MATERIALS ESTIMATING  
**Floors – Estimation Only**

**Lumber Requirements:**

- Single lumber edging for ledger
- Double lumber edging under wall

**Caulking and Sealant Requirements:**

- Every 1200 sqft (111 m<sup>2</sup>) of SIP equals 1 case of Expandable Foam
- Every 2000 sqft (185 m<sup>2</sup>) of SIP requires 1 case of Sealant

**Fasteners:**

- Recommend 2" (50mm) Ring nail or 2" (50mm) screws for connection to panel
- ~ 1.25 times the square footage of SIPs... nailing of spline
- SIP screws use 40% of Floor square footage

# AIR BARRIER

## RECOMMENDED DETAILS FOR AIR BARRIER SEALANTS

All sealants, FOAM (A) or CAULKING (B), should be applied onto the SIP in a continuous rectangular pattern along the outer most edge of the area to be sealed.

(A) A low expansion EXPANDABLE FOAM SEALANT should conform to the AAMA 812-04 standard. Apply a 1/2 inch or a 12.5 mm diameter of a *continuous* bead of expandable foam sealant onto the SIP:

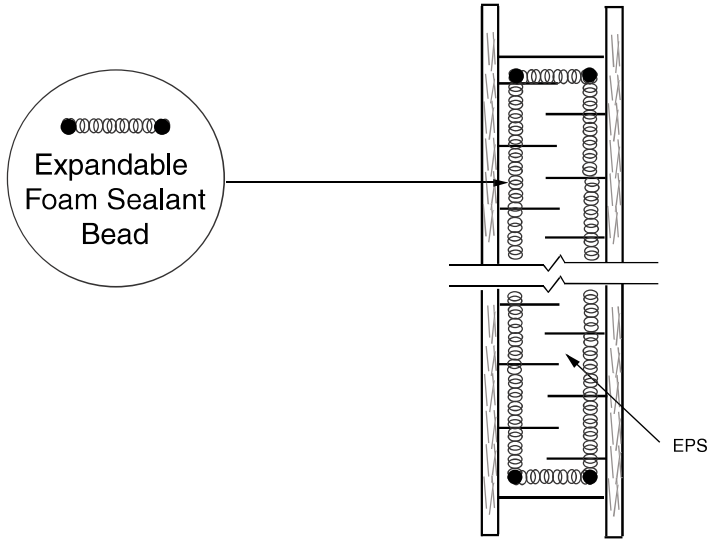

(B) A CAULKING SEALANT should conform to ASTM C920-02 and/or CAN/CGSB 19.13-M. Apply a 3/8 inch or a 10 mm diameter *continuous* bead of caulking onto the lumber spline:

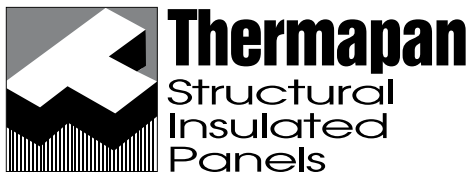
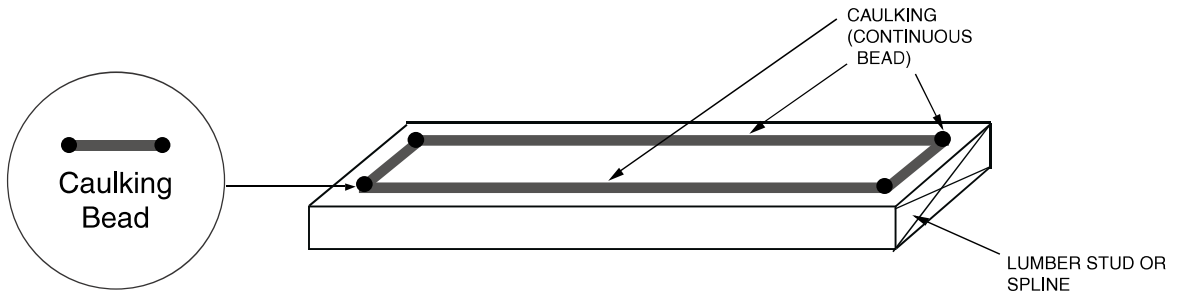

www.thermapan.com  
1-877-443-WALL (9255)

TITLE  <h3 style="text-align: center;">AIR BARRIER DETAILS FOR AIR BARRIER SEALANTS</h3>	PROJECT	
REFERENCE	SCALE  <p style="text-align: center;">N.T.S.</p>	
DATE  <p style="text-align: center;">NOVEMBER 2010</p>	REVISION  <p style="text-align: center;">1</p>	DWG. No.  <p style="text-align: center;">AB-1</p>

# AIR BARRIER

## RECOMMENDED DETAILS FOR SEALING SIP CONNECTIONS

(1) Foam to Foam: Use a low expansion foam sealant.

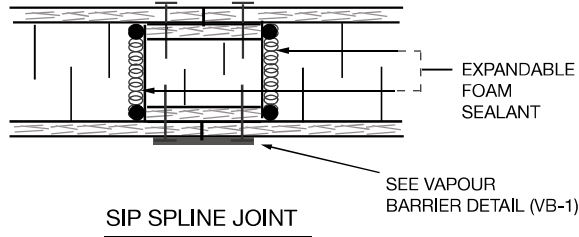

(2) Foam to Wood: Use a low expansion foam sealant.

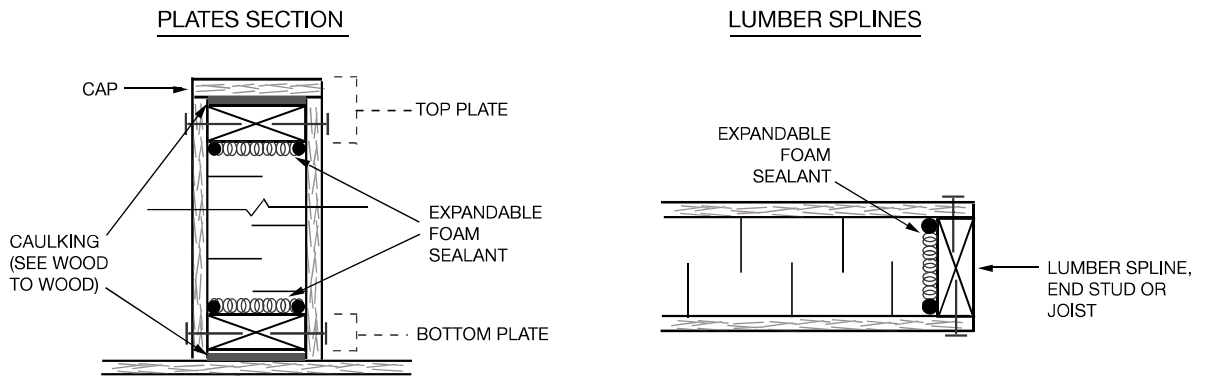

(3) Wood to Wood: Use caulking and a low expansion foam sealant.

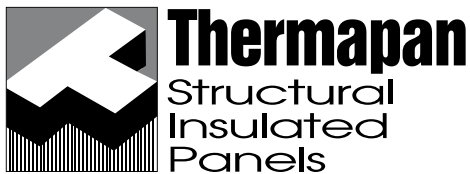
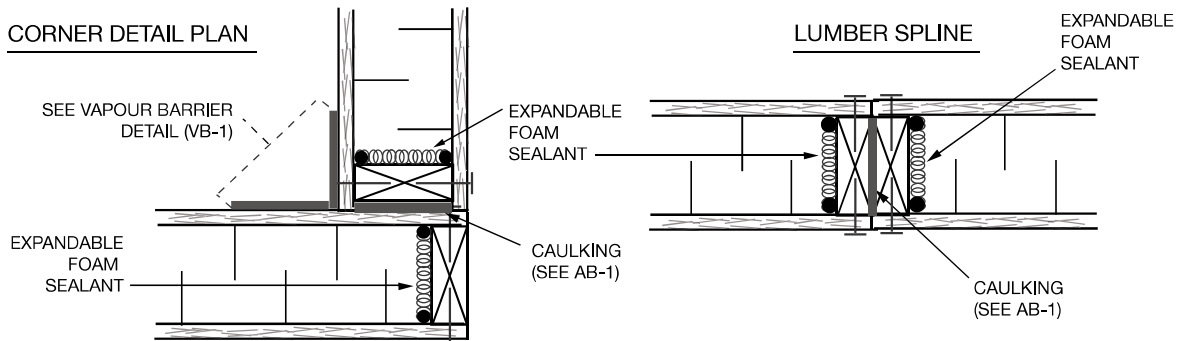

www.thermapan.com  
1-877-443-WALL (9255)

TITLE		PROJECT	
AIR BARRIER DETAILS FOR SEALING SIP CONNECTIONS			
REFERENCE	SCALE		
	N.T.S.		
DATE	REVISION	DWG. No.	
MAY 2020	1	AB-2	

# VAPOUR BARRIER

## RECOMMENDED DETAILS FOR VAPOUR SEALING SIP CONNECTIONS

The function of a vapour barrier is to control the entry of water vapour into the building assembly. Vapour barriers should not be confused with an air barrier.

All SIP seams and connections must be VAPOUR SEALED from the INTERIOR.

These are recommended vapour barrier methods:

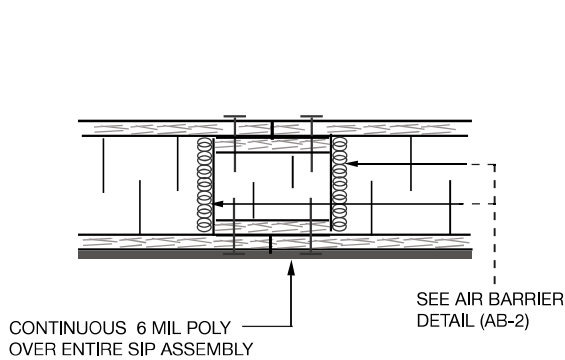

CONTINUOUS 6 MIL POLY  
**RECOMMENDED**

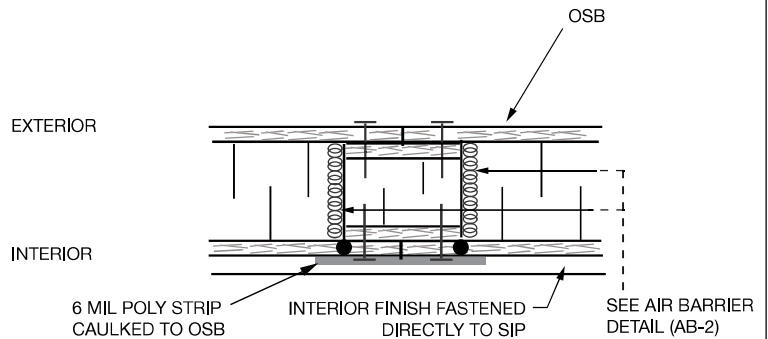

6 MIL POLY STRIPS & CAULKING

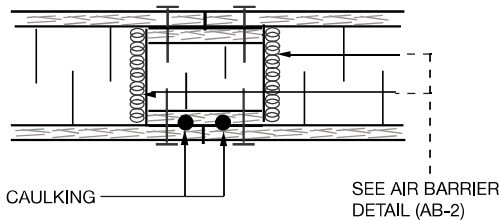

CAULKING

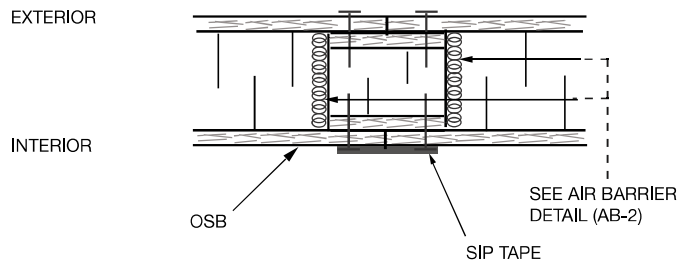

SIP TAPE



www.thermapan.com  
1-877-443-WALL (9255)

TITLE		PROJECT	
VAPOUR BARRIER DETAILS FOR VAPOUR SEALING SIP CONNECTIONS			
REFERENCE	SCALE		
	N.T.S.		
DATE	REVISION	DWG. No.	
MAY 2020	2	VB-1	



SECTION

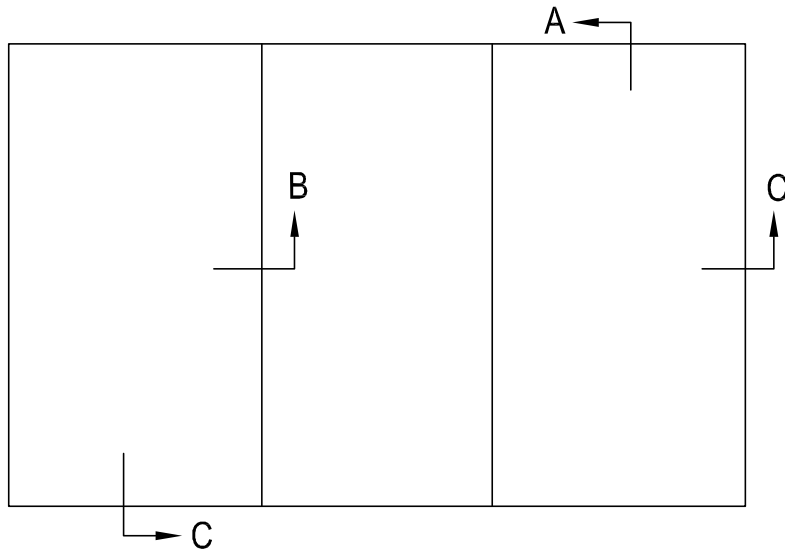

PANEL FLOOR PLAN

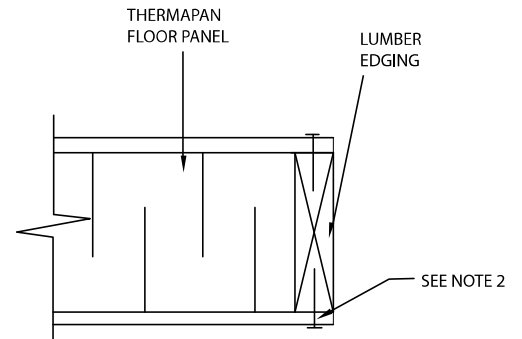

FLOOR SECTION "A"

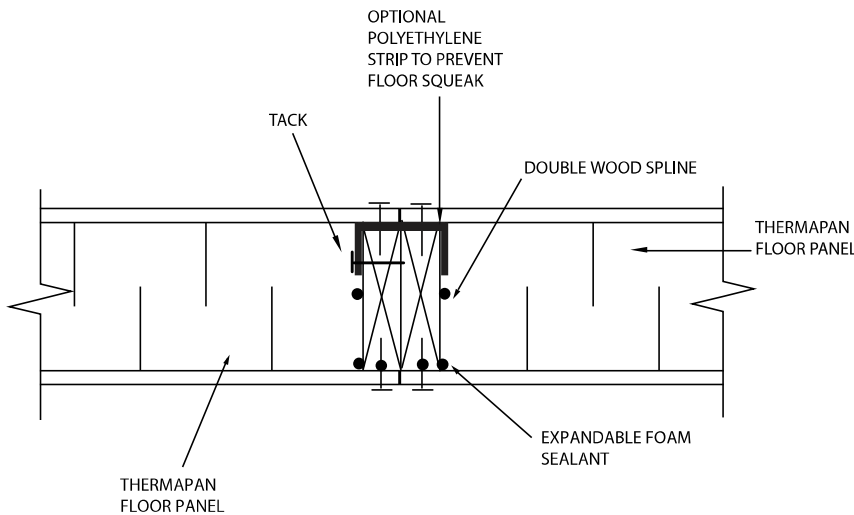

FLOOR SECTION "B"

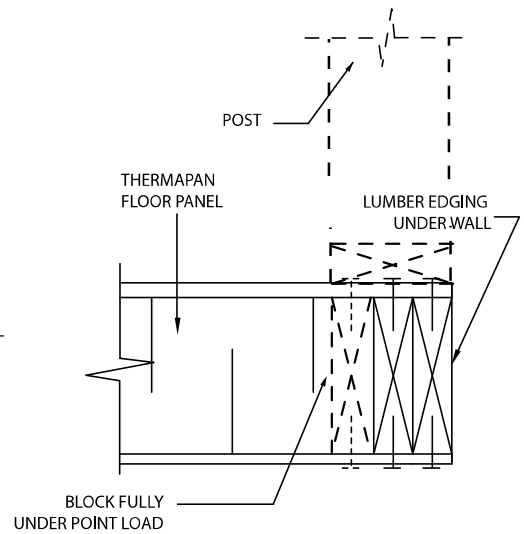

FLOOR SECTION "C"

NOTE: REFER TO AIR BARRIER DETAILS (AB-1 & AB-2).

NOTE 2: REFERENCE FLOOR PANEL FASTENING TABLE ON CONNECTION DESIGN (CD) SHEET OF ENGINEERING DRAWINGS

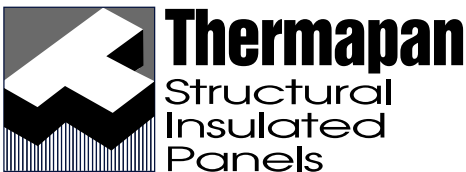

www.thermapan.com  
1-877-443-WALL (9255)

TITLE		
FLOOR PANEL DETAILS		
REFERENCE	SCALE	
	N.T.S.	
DATE	REVISION	DWG. No.
FEBRUARY 2012	9	FL-1

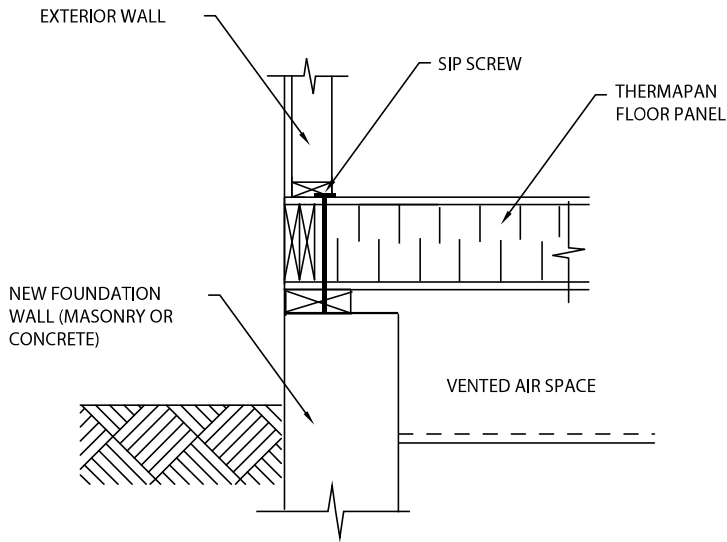

**DETAIL F1**  
FOUNDATION WALL

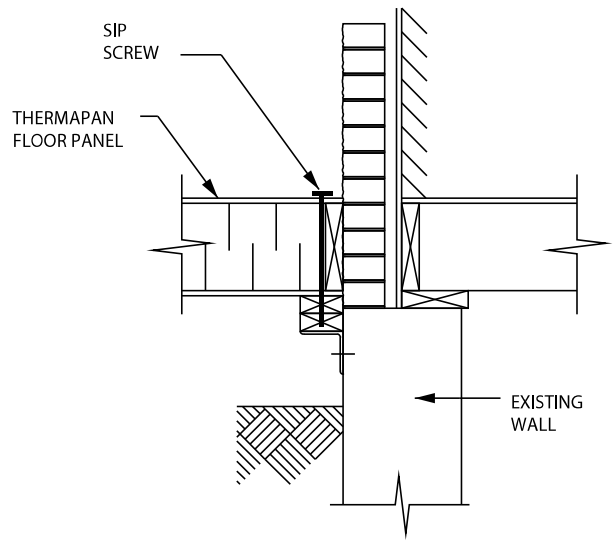

**DETAIL F3**  
NEW FLOOR TO EXISTING WALL

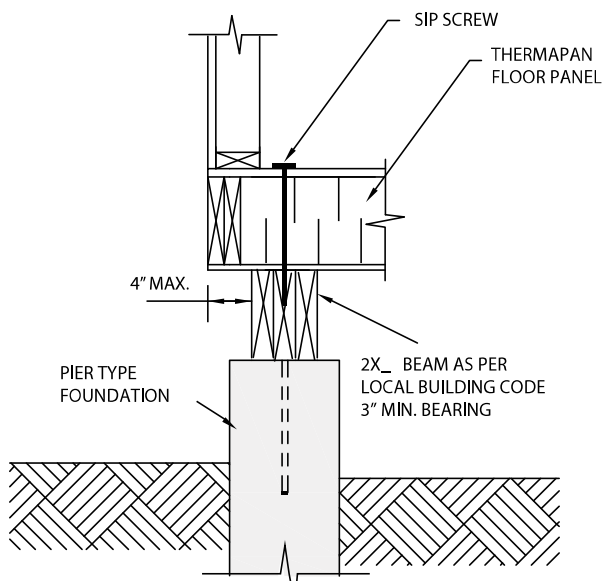

**DETAIL F2**  
PIER

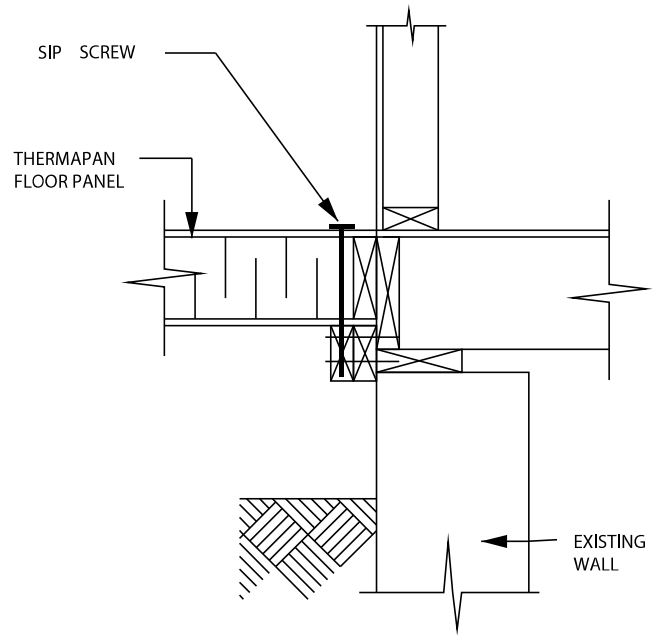

**DETAIL F4**  
NEW FLOOR TO EXISTING WALL

NOTE: REFERENCE FLOOR PANEL FASTENING TABLE ON CONNECTION DESIGN (CD) SHEET OF ENGINEERING DRAWINGS

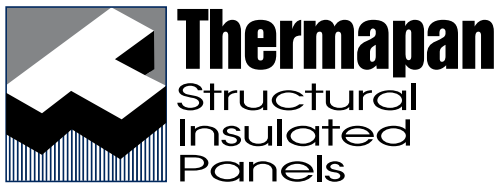

www.thermapan.com  
1-877-443-WALL (9255)

TITLE		PROJECT	
FLOOR PANEL CONNECTIONS (TO FOUNDATION OR EXISTING WALLS)		PROJECT	
		N.T.S.	
REFERENCE	SCALE	N.T.S.	
DATE	REVISION	DWG. No.	
NOVEMBER 2011	2	FL-2	

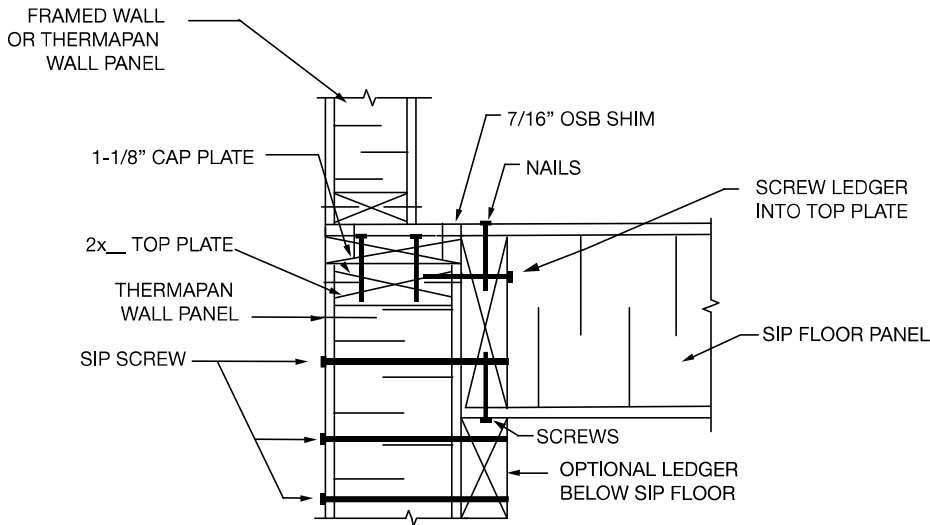

**DETAIL F5**

SUSPENDED SIP FLOOR TO SIP WALL

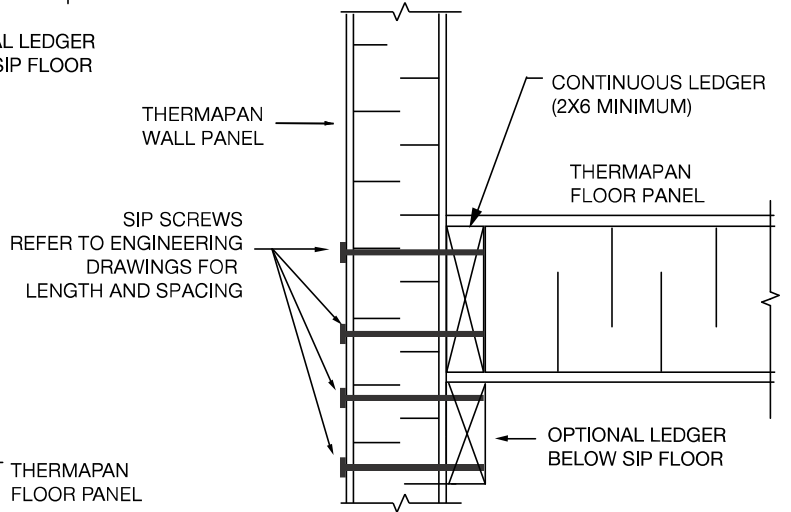

**DETAIL F7**

SIP FLOOR ATTACHED TO SIDE OF SIP WALL

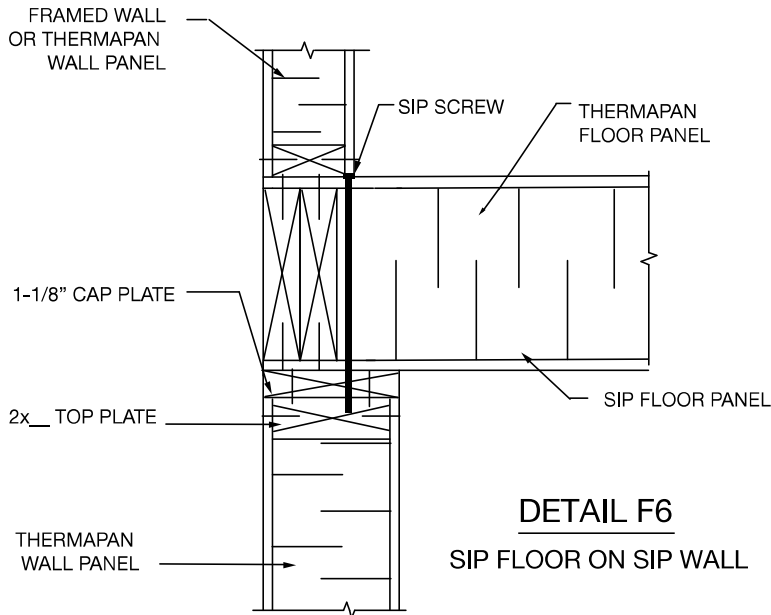

**DETAIL F6**

SIP FLOOR ON SIP WALL

NOTE: REFERENCE FLOOR PANEL FASTENING TABLE ON CONNECTION DESIGN (CD) SHEET OF ENGINEERING DRAWINGS



**Thermapan**  
Structural  
Insulated  
Panels

www.thermapan.com  
1-877-443-WALL (9255)

TITLE		PROJECT	
REFERENCE		SCALE	
		N.T.S.	
DATE		REVISION	DWG. No.
SEPTEMBER 2015		1	FL-3
FLOOR PANEL CONNECTIONS (TO SIP EXTERIOR AND SIP FOUNDATION WALLS)			

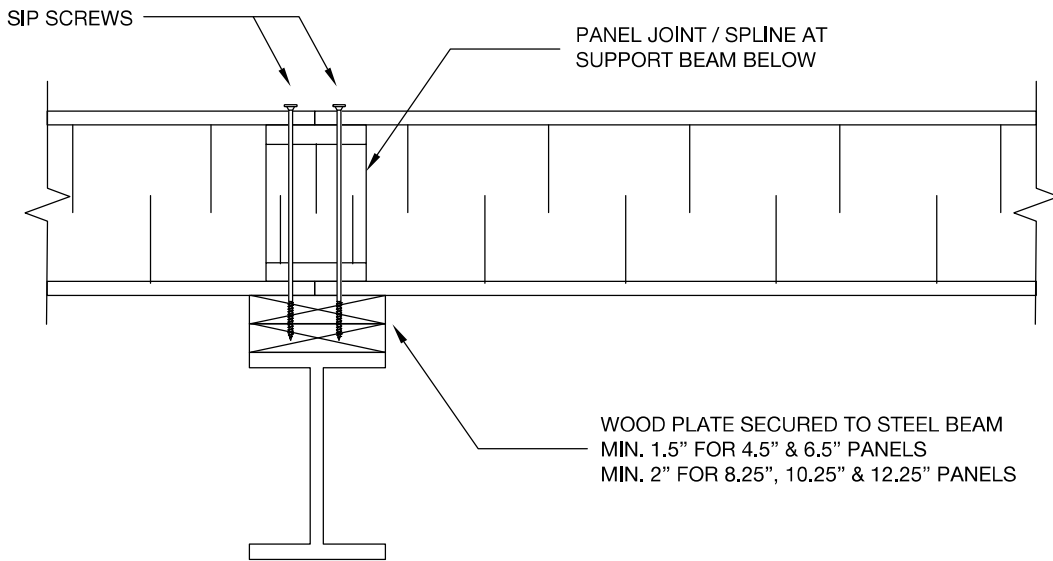

**Thermapan**  
Structural  
Insulated  
Panels

www.thermapan.com  
1-877-443-WALL (9255)

TITLE		FLOOR SIP TO STEEL BEAM CONNECTION		PROJECT
REFERENCE	SCALE	N.T.S.		
DATE	REVISION	DWG. No.		
MARCH 2026		FL-4		